

焊接式弯头 (45°) 45° Welded Elbow

DIN

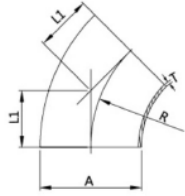

Size	A	R	L1	T
DN10	12/13	26	10.7	1.5
DN15	18/19	35	14.5	1.5
DN20	22/23	40	16.5	1.5
DN25	28/29	50	20.7	1.5
DN32	34/35	55	22.8	1.5
DN40	40/41	60	24.8	1.5
DN50	52/53	70	29	1.5
DN65	70	80	33.2	2
DN80	85	90	37.3	2
DN100	104	100	41.5	2
DN125	129	187.5	77.5	2
DN150	154	225	93.2	2
DN200	204	300	124.3	2
DN250	254	325	155.3	2
DN300	306	450	186.4	3

长型焊接式弯头 (45°) 45° Long Welded Elbow

DIN

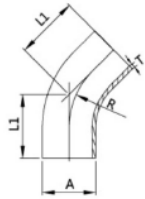

Size	A	R	L1	T
DN10	12/13	26	35.8	1.5
DN15	18/19	35	39.5	1.5
DN20	22/23	40	41.6	1.5
DN25	28/29	50	60.7	1.5
DN32	34/35	55	62.8	1.5
DN40	40/41	60	64.9	1.5
DN50	52/53	70	69	1.5
DN65	70	80	73	2
DN80	85	90	92.3	2
DN100	104	100	96.4	2
DN125	129	187.5	135.2	2
DN150	154	225	156.7	2

焊接式弯头 (90°) 90° Welded Elbow

DIN

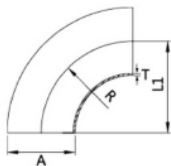

Size	A	R	L1	T
DN10	12/13	26	26	1.5
DN15	18/19	35	35	1.5
DN20	22/23	40	40	1.5
DN25	28/29	50	50	1.5
DN32	34/35	55	55	1.5
DN40	40/41	60	60	1.5
DN50	52/53	70	70	1.5
DN65	70	80	80	2
DN80	85	90	90	2
DN100	104	100	100	2
DN125	129	187	187	2
DN150	154	225	225	2
DN200	204	300	300	2
DN250	254	325	254	2
DN300	306	450	306	3

长型焊接式弯头 (90°) 90° Long Welded Elbow

DIN

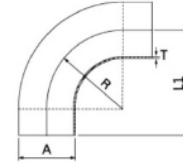

Size	A	R	L1	T
DN10	12/13	26	38/51	1.5
DN15	18/19	35	47/60	1.5
DN20	22/23	40	52/65	1.5
DN25	28/29	50	70/90	1.5
DN32	34/35	55	78/95	1.5
DN40	40/41	60	85/100	1.5
DN50	52/53	70	97/110	1.5
DN65	70	80	110/120	2
DN80	85	90	118/145	2
DN100	104	100	140/155	2
DN125	129	187	227	2
DN150	154	225	265	2

焊接式弯头 (180°) 180° Welded Elbow

DIN

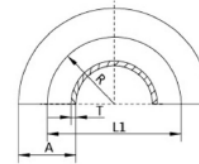

Size	A	R	L1	T
DN10	12/13	26	52	1.5
DN15	18/19	35	70	1.5
DN20	22/23	40	80	1.5
DN25	28/29	50	100	1.5
DN32	34/35	55	110	1.5
DN40	40/41	60	120	1.5
DN50	52/53	70	140	1.5
DN65	70	80	160	2
DN80	85	90	180	2
DN100	104	100	200	2
DN125	129	187.5	375	2
DN150	154	225	450	2
DN200	204	300	600	2
DN250	254	375	750	2
DN300	306	450	900	3

短型焊接式三通 Short Welded Tee

DIN

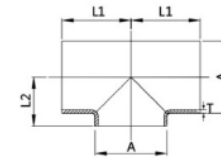

Size	A	L1	L2	T
DN10	12/13	26	7.5	1.5
DN15	18/19	35	10.5	1.5
DN20	22/23	40	12.5	1.5
DN25	28/29	50	16	1.5
DN32	34/35	55	19.5	1.5
DN40	40/41	60	22.5	1.5
DN50	52/53	70	30	1.5
DN65	70	80	39.5	2
DN80	85	90	47.5	2
DN100	104	100	58	2
DN100	101.6	150	56	2
DN125	129	187	70.5	2
DN150	154	225	83	2
DN200	204	300	115	2
DN250	254	216	140	2
DN300	306	254	165	3

焊接式三通 Welded Tee

DIN

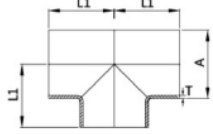

Size	A	L1	T
DN10	12/13	26	1.5
DN15	18/19	35	1.5
DN20	22/23	40	1.5
DN25	28/29	50	1.5
DN32	34/35	55	1.5
DN40	40/41	60	1.5
DN50	52/53	70	1.5
DN65	70	80	2
DN80	85	90	2
DN100	104	100	2
DN125	129	187	2
DN150	154	225	2
DN200	204	300	2
DN250	254	216	2
DN300	306	254	3

长型焊接变径三通 Long Welded Reducing Tee

DIN

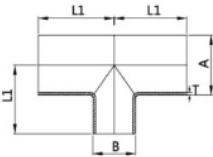

DN	AxB	L1	T
25-20	28x22	50	1.5
32-25	34x28	55	1.5
40-25	40x28	60	1.5
40-32	40x34	60	1.5
50-25	52x28	70	2
50-32	52x34	70	2
50-40	52x40	70	2
65-25	70x28	80	2
65-32	70x34	80	2
65-40	70x40	80	2
65-50	70x52	80	2
80-25	85x28	90	2
80-32	85x34	90	2
80-40	85x40	90	2
80-50	85x52	90	2
80-65	85x70	90	2
100-25	104x28	100	2
100-32	104x34	100	2
100-40	104x40	100	2
100-50	104x52	100	2
100-65	104x70	100	2
100-80	104x85	100	2
125-25	129x28	187.5	2
125-32	129x104	187.5	2
125-40	129x104	187.5	2
125-50	129x104	187.5	2
125-65	129x104	187.5	2
125-80	129x104	187.5	2
125-100	129x104	187.5	2
150-32	154x34	225	2
150-40	154x40	225	2
150-50	154x52	225	2
150-65	154x70	225	2
150-80	154x85	225	2
150-100	154x104	225	2
150-125	154x129	225	2

短型焊接变径三通 Short Welded Reducing Tee

DIN

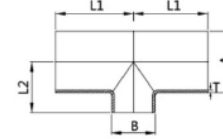

DN	AxB	L1	L2	T
25-20	28x22	50	17	1.5
32-25	34x28	55	19.5	1.5
40-25	40x28	60	22.5	1.5
40-32	40x34	60	22.5	1.5
50-25	52x28	70	29.5	2
50-32	52x34	70	29.5	2
50-40	52x40	70	29.5	2
65-25	70x28	80	39	2
65-32	70x34	80	39	2
65-40	70x40	80	39	2
65-50	70x52	80	46.5	2
80-25	85x28	90	46.5	2
80-32	85x34	90	46.5	2
80-40	85x40	90	46.5	2
80-50	85x52	90	46.5	2
80-65	85x70	90	46.5	2
100-25	104x28	100	56	2
100-32	104x34	100	56	2
100-40	104x40	100	56	2
100-50	104x52	100	56	2
100-65	104x70	100	56	2
100-80	104x85	100	56	2
125-25	129x28	187.5	68.5	2
125-32	129x104	187.5	68.5	2
125-40	129x104	187.5	68.5	2
125-50	129x104	187.5	68.5	2
125-65	129x104	187.5	68.5	2
125-80	129x104	187.5	68.5	2
125-100	129x104	187.5	68.5	2
150-32	154x34	225	81	2
150-40	154x40	225	81	2
150-50	154x52	225	81	2
150-65	154x70	225	81	2
150-80	154x85	225	81	2
150-100	154x104	225	81	2
150-125	154x129	225	81	2

焊接式四通 Welded Cross

DIN

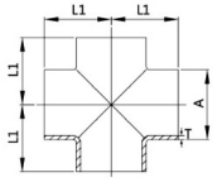

Size	A	L1	T
DN10	12/13	26	1.5
DN15	18/19	35	1.5
DN20	22/23	40	1.5
DN25	28/29	50	1.5
DN32	34/35	55	1.5
DN40	40/41	60	1.5
DN50	52/53	70	1.5
DN65	70	80	2
DN80	85	90	2
DN100	104	100	2
DN125	129	187	2
DN150	154	225	2
DN200	204	300	2
DN250	254	216	2
DN300	306	254	3

焊接式大小头 Welded Reducer

DIN

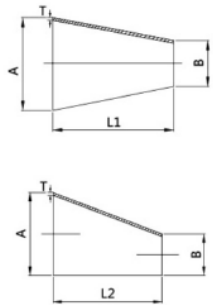

Size	A	B	L1	L2	T
DN15/10	18/19	12/13	11		1.5×1.5
DN20/10	22/23	12/13	18		1.5×1.5
DN20/15	22/23	18/19	7		1.5×1.5
DN25/15	28/29	18/19	18		1.5×1.5
DN25/20	28/29	22/23	11		1.5×1.5
DN32/20	34/35	22/23	22		1.5×1.5
DN32/25	34/35	28/29	11	16.5	1.5×1.5
DN40/20	40/41	22/23	33		1.5×1.5
DN40/25	40/41	28/29	22	33	1.5×1.5
DN40/32	40/41	34/35	22	16.5	1.5×1.5
DN50/25	52/53	28/29	44	66	1.5×1.5
DN50/32	52/53	34/35	33	49.5	1.5×1.5
DN50/40	52/53	40/41	22	33	1.5×1.5
DN65/25	70	28/29	73		2×1.5
DN65/32	70	34/35	62		2×1.5
DN65/40	70	40/41	51	77	2×1.5
DN65/50	70	52/53	29	44	2×1.5
DN80/40	85	40/41	78		2×1.5
DN80/50	85	52/53	56	85	2×1.5
DN80/65	85	70	27	41.2	2×2
DN100/50	104	52/53	90	137.5	2×1.5
DN100/65	104	70	61	93.5	2×2
DN100/80	104	85	34	52.5	2×2
DN125/80	129	85	80		2×2
DN125/100	129	104	45		2×2
DN150/100	129	104	90		2×2
DN150/125	154	129	45		2×2
DN200/150	204	154	90		2×2

卡箍式大小头 Clamped Reducer

DIN

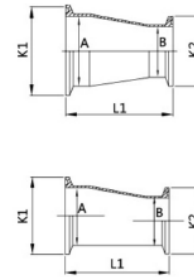

Size	A	B	K1×K2	L1
DN20/15	22/23	18/19	34×34	86
DN25/20	28/29	22/23	50.5×34	86
DN32/20	34/35	22/23	50.5×34	106
DN32/25	34/35	28/29	50.5×50.5	106
DN40/20	40/41	22/23	50.5×34	128
DN40/25	40/41	28/29	50.5×50.5	128
DN40/32	40/41	34/35	50.5×50.5	128
DN50/25	52/53	28/29	64×50.5	141
DN50/32	52/53	34/35	64×50.5	141
DN50/40	52/53	40/41	64×50.5	141
DN65/25	70	28/29	91×50.5	151
DN65/32	70	34/35	91×50.5	151
DN65/40	70	40/41	91×50.5	146
DN65/50	70	52/53	91×64	146
DN80/40	85	40/41	106×50.5	166
DN80/50	85	52/53	106×64	151
DN80/65	85	70	106×91	146
DN100/50	104	52/53	119×64	192
DN100/65	104	70	119×91	159
DN100/80	104	85	119×106	152

由任式大小头 Union Reducer

DIN

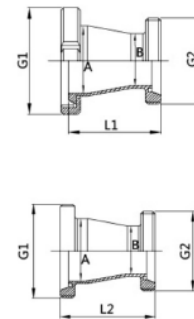

Size	A	B	G1	G2	L1	L2
DN20/15	22/23	18/19	RD44×1/6	RD34×1/8	93	98
DN25/20	28/29	22/23	RD52×1/6	RD44×1/6	97	101
DN32/20	34/35	22/23	RD58×1/6	RD44×1/6	117	121
DN32/25	34/35	28/29	RD58×1/6	RD52×1/6	118	122
DN40/20	40/41	22/23	RD65×1/6	RD44×1/6	139	143
DN40/25	40/41	28/29	RD65×1/6	RD52×1/6	140	144
DN40/32	40/41	34/35	RD65×1/6	RD58×1/6	140	144
DN50/25	52/53	28/29	RD78×1/6	RD52×1/6	153	157
DN50/32	52/53	34/35	RD78×1/6	RD58×1/6	153	157
DN50/40	52/53	40/41	RD78×1/6	RD65×1/6	153	157
DN65/25	70	28/29	RD95×1/6	RD52×1/6	163	169
DN65/32	70	34/35	RD95×1/6	RD58×1/6	163	169
DN65/40	70	40/41	RD95×1/6	RD65×1/6	158	164
DN65/50	70	52/53	RD95×1/6	RD78×1/6	158	164
DN80/40	85	40/41	RD110×1/4	RD65×1/6	181	187
DN80/50	85	52/53	RD110×1/4	RD78×1/6	166	172
DN80/65	85	70	RD110×1/4	RD95×1/6	183	174
DN100/50	104	52/53	RD130×1/4	RD78×1/6	195	209
DN100/65	104	70	RD130×1/4	RD95×1/6	174	178
DN100/80	104	85	RD130×1/4	RD110×1/4	170	174

焊接式弯头 (45°) 45° Welded Elbow

SMS

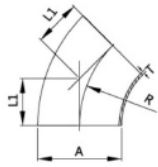

Size	A	R	L1	T
25	25.4	38.1	15.5	1.25/1.5
38	38.1	57.2	23.6	1.25/1.5
51	50.8	76.2	31.6	1.25/1.5
63	63.5	95.3	39.5	1.5/2
76	76.2	114.3	47.2	1.6/2
102	101.6	152.4	63	2
127	127	190.5	78.9	2
152.4	152.4	228.6	94.7	2
203.2	203.2	305	126.3	2

长型焊接式弯头 (45°) 45° Long Welded Elbow

SMS

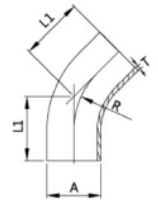

Size	A	R	L1	T
25	25.4	38.7	42.5	1.25/1.5
38	38.1	57.2	56.8	1.25/1.5
51	50.8	76.2	68.6	1.25/1.5
63	63.5	95.2	78.4	1.65/2
76	76.2	114.3	85.2	1.6/2
102	101.6	152.4	103	2
127	127	190.5	142.4	2
152.4	152.4	228.6	158.2	2
203.2	203.2	305	202.5	2

焊接式弯头 (90°) 90° Welded Elbow

SMS

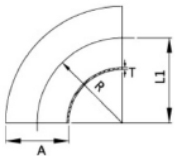

Size	A	R	L1	T
25	25.4	38.1	38.1	1.25/1.5
32	31.8	47.7	47.7	1.25/1.5
38	38.1	57.2	57.1	1.25/1.5
51	50.8	76.2	76.2	1.25/1.5
63	63.5	95.2	95.2	1.5/2
76	76.2	114.3	114.3	1.65/2
102	101.6	152.4	152.4	2
104	104	152.4	152.4	2
127	127	190.5	190.5	2
152.4	152.4	228.6	228.6	2
203.2	203.2	305	305	2

长型焊接式弯头 (90°) 90° Long Welded Elbow

SMS

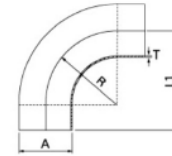

Size	A	R	L1	T
25	25.4	38.7	55	1.25/1.5
38	38.1	57.2	70	1.25/1.5
51	50.8	76.2	82	1.25/1.5
63	63.5	95.2	105	1.5/2
76	76.2	114.3	110	1.6/2
102	101.6	152.4	150	2
104	104	152.4	150	2
127	129	190.5	254	2
152.4	152.4	228.6	292	2
203.2	203.2	305	381	2

焊接变径平口三通 Reducing Welded Flat Tee

SMS

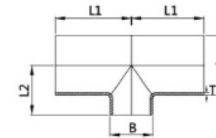

Size	AxB	L1	L2	T
38-25	38×25	70	21	1.5
51-25	51×25	82	29	1.5
51-38	51×38	82	29	1.5
63.5-25	63.5×25	105	36	1.5
63.5-38	63.5×38	105	36	1.5
63.5-51	63.5×51	105	36	1.5
76-25	76.1×25	110	44	1.6
76-38	76.1×38	110	44	1.6
76-51	76.1×51	110	44	1.6
76-63.5	76.1×63.5	110	44	1.6
101.6-25	101.6×25	150	58	2
101.6-38	101.6×38	150	58	2
101.6-51	101.6×51	150	58	2
101.6-63.5	101.6×63.5	150	58	2
101.6-76	101.6×76.1	150	58	2

焊接等径平口三通 Equal Welded Flat Tee

SMS

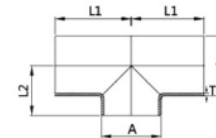

Size	A	L1	L2	T
25	25	55	15	1.25/1.5
38	38	70	21	1.25/1.5
51	51	82	29	1.25
63.5	63.5	105	36	1.5
76	76.1	110	44	1.6
101.6	101.6	150	58	2
127	127	190.5	72	2
152.4	153.4	228.6	85	2
203.2	203.2	305	110	2

焊接变径四通 Reducing Welded Cross

SMS

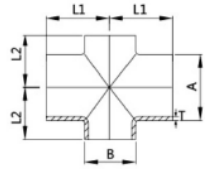

Size	AxB	L1	L2	T
38-25	38×25	70	21	1.25
51-25	51×25	82	29	1.25
51-38	51×38	82	29	1.25
63.5-25	63.5×25	105	36	1.5
63.5-38	63.5×38	105	36	1.5
63.5-51	63.5×51	105	36	1.5
76-25	76.1×25	110	44	1.6
76-38	76.1×38	110	44	1.6
76-51	76.1×51	110	44	1.6
76-63.5	76.1×63.5	110	44	1.6
101.6-25	101.6×25	150	58	2
101.6-38	101.6×38	150	58	2
101.6-51	101.6×51	150	58	2
101.6-63.5	101.6×63.5	150	58	2
101.6-76	101.6×76.1	150	58	2

等径三通 Equal Tee

SMS

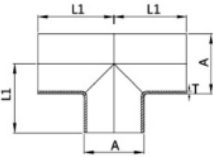

Size	A	L1	T
25	25	55	1.25
38	38	70	1.25
51	51	81	1.25
63.5	63.5	105	1.5
76	76.1	110	1.6
101.6	101.6	150	2
127	127	190.5	2
152.4	152.4	228.6	2
203.2	203.2	305.2	2

等径三通 Equal Tee

SMS

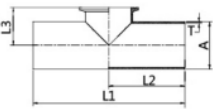

Size	A	L1	L2	L3	T
25	25	110	55	26.7	1.2
38	38	140	70	33.7	1.2
51	51	164	82	41.2	1.2
63.5	63.5	210	105	48	1.6
76	76.1	220	110	54.2	1.6
101.6	101.6	300	150	70.5	2

焊接式大小头 Welded Reducer

SMS

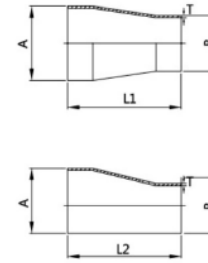

Size	AxB	L1	L2	T
38.1-25.4	38.1-25.4	39	46	1.25×1.25 1.5×1.5
50.8-25.4	50.8-25.4	57	68	1.25×1.25 1.5×1.5
50.8-38.1	50.8-38.1	39	47	1.25×1.25 1.5×1.5
63.5-25.4	63.5-25.4	74	92	1.65×1.65 2×2
63.5-38.1	63.5-38.1	57	70	1.65×1.65 2×2
63.5-50.8	63.5-50.8	39	44	1.65×1.65 2×2
76.2-25.4	76.2-25.4	92	117	1.65×1.65 2×2
76.2-38.1	76.2-38.1	74	92	1.65×1.65 2×2
76.2-50.8	76.2-50.8	57	68	1.65×1.65 2×2
76.2-63.5	76.2-63.5	39	47	1.65×1.65 2×2
101.6-50.8	101.6-50.8	95	117	2×1.25
101.6-63.5	101.6-63.5	78	94	2×1.5
101.6-76.2	101.6-76.2	60	74	2×1.65

同心大小头 (加长型) Concentric Reducers (Long)

SMS

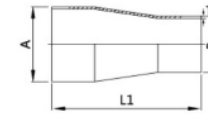

Size	AxB	L1	T
25-19	25×19	85	1.25×1.25 1.5×1.5
38-19	38×19	85	1.25×1.25 1.5×1.5
38-25	38×25	99	1.25×1.25 1.5×1.5
51-25	51×25	117	1.25×1.25 1.5×1.5
51-38	51×38	99	1.25×1.25 1.5×1.5
63.5-25	63.5×25	134	1.65×1.65 2×2
63.5-38	63.5×38	117.5	1.65×1.65 2×2
63.5-51	63.5×51	99	1.65×1.65 2×2
76.1-25	76.1×25	152	1.65×1.65 2×2
76.1-38	76.1×38	134	1.65×1.65 2×2
76.1-51	76.1×51	117	1.65×1.65 2×2
76.1-63	76.1×63.5	99	1.65×1.65 2×2
102-51	102×51	155	2×1.25
102-63	102×63.5	138	2×1.5
102-76	102×76.1	120	2×1.65

偏心大小头 (加长型) Eccentric Reducers (Long)

SMS

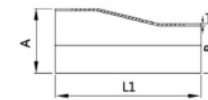

Size	AxB	L1	T
38-25	38×25	106	1.25×1.25 1.5×1.5
51-25	51×25	128	1.25×1.25 1.5×1.5
51-38	51×38	107	1.25×1.25 1.5×1.5
63.5-25	63.5×25	150.5	1.65×1.65 2×2
63.5-38	63.5×38	130	1.65×1.65 2×2
63.5-51	63.5×51	104	1.65×1.65 2×2
76.1-38	76.1×38	149	1.65×1.65 2×2
76.1-51	76.1×51	128	1.65×1.65 2×2
76.1-63	76.1×63.5	107	1.65×1.65 2×2
101-51	101.6×51	177	2×2
101-63	101.6×63.5	154	2×2
101-76	101.6×76.1	134	2×2
102-51	102×51	177	2×2
102-63	102×63.5	154	2×2
102-76	102×76.1	134	2×2

焊接式弯头 (45°) 45° Welded Elbow

3A

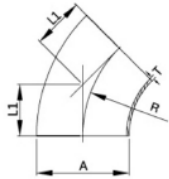

Size	A	R	L1	T
1/2"	12.7	19	7.1	1.65
3/4"	19.1	28.6	11.9	1.65
1"	25.4	38.1	15.8	1.65
1 1/4"	31.8	47.7	19.8	1.65
1 1/2"	38.1	57.2	23.8	1.65
2"	50.8	76.2	31.8	1.65
2 1/2"	63.5	95.3	39.6	1.65
3"	76.2	114.3	47.6	1.65
4"	101.6	152.4	63.5	2.1
6"	152.4	228.6	64.7	2.8
8"	203.2	305.2	126.4	2.8
10"	254	381	157.8	2.8
12"	304.8	457	189.3	2.8

长型焊接式弯头 (45°) 45° Long Welded Elbow

3A

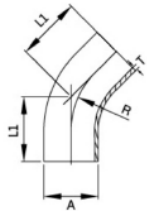

Size	A	R	L1	T
1/2"	12.7	19	57.2	1.65
3/4"	19.1	28.6	57.2	1.65
1"	25.4	38.1	30.2	1.65
1 1/4"	31.8	47.7	41.3	1.65
1 1/2"	38.1	57.2	41.3	1.65
2"	50.8	76.2	58.7	1.65
2 1/2"	63.5	95.3	76.2	1.65
3"	76.2	114.3	93.7	1.65
4"	101.6	152.4	122.2	1.65
6"	152.4	228.6	158.2	2.8

焊接式弯头 (90°) 90° Welded Elbow

3A

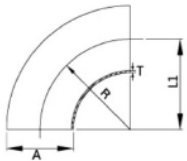

Size	A	R	L1	T
1/2"	12.7	19.1	19.1	1.65
3/4"	19.1	28.6	28.6	1.65
1"	25.4	38.1	38.1	1.65
1 1/4"	31.8	47.7	47.7	1.65
1 1/2"	38.1	57.2	57.2	1.65
2"	50.8	76.2	76.2	1.65
2 1/2"	63.5	95.3	95.3	1.65
3"	76.2	114.3	114.3	1.65
4"	101.6	152.4	152.4	1.65
5"	127	190.5	190.5	2
6"	152.4	228.6	228.6	2.8
8"	203.2	304.8	304.8	2.8
10"	254	381	381	2.8
12"	304.8	457.2	457.2	2.8

长型焊接式弯头 (90°) 90° Long Welded Elbow

3A

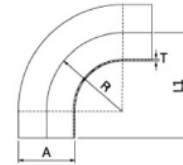

Size	A	R	L1	T
1/2"	12.7	19.1	25.4	1.65
3/4"	19.1	28.6	38.1	1.65
1"	25.4	38.1	52.4	1.65
1 1/4"	31.8	47.7	69.7	1.65
1 1/2"	38.1	57.2	74.6	1.65
2"	50.8	76.2	103.2	1.65
2 1/2"	63.5	95.3	131.8	1.65
3"	76.2	114.3	160.3	1.65
4"	101.6	152.4	211.1	2
6"	152.4	228.6	292.1	2.8
8"	203.2	228.6	304.8	2.8

卡箍式弯头 (45°) 45° Clamped Elbow

3A

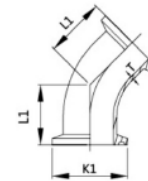

Size	L1	K1	T
1"	28.5	50.5	1.65
1 1/2"	36.5	50.5	1.65
2"	44.5	64	1.65
2 1/2"	52.3	77	1.65
3"	60.3	91	1.65
4"	76.2	119	2.1

卡箍式弯头 (90°) 90° Clamped Elbow

3A

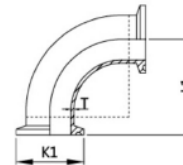

Size	L1	K1	T
1"	50.8	50.5	1.65
1 1/2"	69.9	50.5	1.65
2"	88.9	64	1.65
2 1/2"	108	77	1.65
3"	127	91	1.65
4"	168.2	119	2.1

焊接式弯头 (180°) 180° Welded Elbow

3A

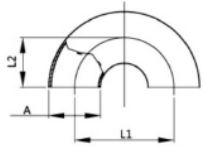

Size	A	L1	L2
1"	25.4	76.2	38.1
1 1/2"	38.1	114.3	57.2
2"	50.8	152.4	76.2
2 1/2"	63.5	190.5	95.3
3"	76.2	228.6	114.3
4"	101.6	304.8	152.4

焊接式短三通 Short Welded Tee

3A

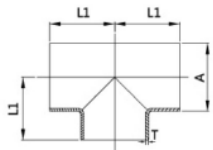

Size	A	L1	T
1/2"	12.7	19	1.65
3/4"	19	28.6	1.65
1"	25.4	28.6	1.65
1 1/4"	31.8	35	1.65
1 1/2"	38.1	42	1.65
2"	50.8	52.3	1.65
2 1/2"	63.5	59.5	1.65
3"	76.2	65.9	1.65
4"	101.6	87.3	2.11
6"	152.4	127	2.8
8"	203.2	178	2.8
10"	254	216	2.8

长型焊接式三通 Long Welded Tee

3A

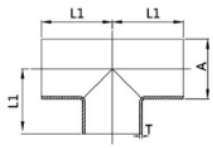

Size	A	L1	T
1/2"	12.7	47.6	1.65
3/4"	19	47.6	1.65
1"	25.4	47.6	1.65
1 1/4"	31.8	55	1.65
1 1/2"	38.1	57.2	1.65
2"	50.8	76.2	1.65
2 1/2"	63.5	76.2	1.65
3"	76.2	82.6	1.65
4"	101.6	98.4	2.11
6"	152.4	143	2.8
8"	203.2	178	2.8
10"	254	216	2.8

卡箍式三通 Clamped Tee

3A

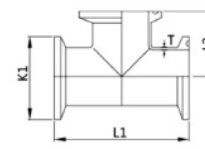

Size	L1	L2	K1	T
1"	120.6	60.3	50.5	1.65
1 1/2"	139.8	69.9	50.5	1.65
2"	177.8	88.9	64	1.65
2 1/2"	177.8	88.9	77	1.65
3"	190.6	95.3	91	1.65
4"	228.4	114.2	119	2.1

焊接式短四通 Short Welded Cross

3A

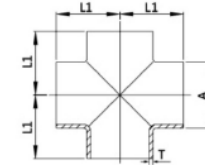

Size	A	L1	T
1"	25.4	28.6	1.65
1 1/4"	31.8	38	1.65
1 1/2"	38.1	42.1	1.65
2"	50.8	52.4	1.65
2 1/2"	63.5	54.5	1.65
3"	76.2	65.9	1.65
4"	101.6	87.3	2.11

长型焊接式四通 Long Welded Cross

3A

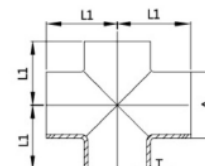

Size	A	L1	T
1/2"	12.7	76.2	1.65
3/4"	19	47.6	1.65
1"	25.4	47.6	1.65
1 1/4"	31.8	55	1.65
1 1/2"	38.1	57.2	1.65
2"	50.8	76.2	1.65
2 1/2"	63.5	76.2	1.65
3"	76.2	82.6	1.65
4"	101.6	98.4	2.11
6"	152.4	127	2.77

焊接式大小头Welded Reducer

3A

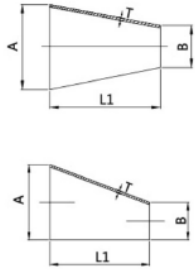

Size	AxB	L1	T
1"-3/4"	25.4×19	25.4	1.65×1.65
1 1/2"-3/4"	38.1×19	76.2	1.65×1.65
1 1/2"-1"	38.1×25.4	50.8	1.65×1.65
2"-1"	50.8×25.4	101.6	1.65×1.65
2"-1 1/2"	50.8×38.1	50.8	1.65×1.65
2 1/2"-1"	63.5×25.4	152.4	1.65×1.65
2 1/2"-1 1/2"	63.5×38.1	101.6	1.65×1.65
2 1/2"-2"	63.5×50.8	50.8	1.65×1.65
3"-1"	76.2×25.4	203.2	1.65×1.65
3"-1 1/2"	76.2×38.1	152.4	1.65×1.65
3"-2"	76.2×50.8	101.6	1.65×1.65
3"-2 1/2"	76.2×63.5	50.8	1.65×1.65
4"-1 1/2"	101.6×38.1	254	2.11×1.65
4"-2"	101.6×50.8	203.2	2.11×1.65
4"-2 1/2"	101.6×63.5	152.4	2.11×1.65
4"-3"	101.6×76.2	101.6	2.11×1.65
6"-3"	152.4×76.2	140	2.77×1.65
6"-4"	152.4×101.6	140	2.77×2.11

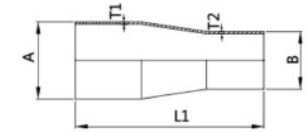
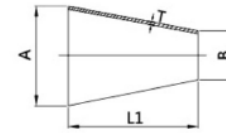

同心大小头
Concentric Reducer

3A

Size	AxB	L1	T
1/2"×1/4"	12.7×6.35	25.4	1.65
1/2"×3/8"	12.7×9.53	25.4	1.65
3/4"×1/2"	19.1×12.7	25.4	1.65
3/4"×3/8"	19.1×9.53	25.4	1.65
1"×1/2"	25.4×12.7	38.1	1.65
1"×3/8"	25.4×9.53	38.1	1.65
1"×3/4"	25.4×19.1	25.4	1.65
1.5"×1/2"	38.1×12.7	63.5	1.65
1.5"×3/4"	38.1×19.1	50.8	1.65
1.5"×1"	38.1×25.4	50.8	1.65
2"×1/2"	50.8×12.7	114.3	1.65
2"×3/4"	50.8×19.1	101.6	1.65
2"×1"	50.8×25.4	101.6	1.65
2"×1.5"	50.8×38.1	50.8	1.65
2.5"×1"	63.5×25.4	152.4	1.65
2.5"×1.5"	63.5×38.1	101.6	1.65
2.5"×2"	63.5×50.8	50.8	1.65
3"×1"	76.2×25.4	203.2	1.65
3"×1.5"	76.2×38.1	152.4	1.65
3"×2"	76.2×50.8	101.6	1.65
3"×2.5"	76.2×63.2	50.8	1.65
4"×1"	101.6×25.4	304.8	2.1
4"×1.5"	101.6×38.1	254	2.1
4"×2"	101.6×50.8	203.2	2.1
4"×2.5"	101.6×63.2	152.4	2.1
4"×3"	101.6×76.2	101.6	2.1
5"×4"	127×101.6	70	2.77
6"×3"	152.4×76.2	241.3	2.77
6"×4"	152.4×101.6	139.7	2.77

同心大小头(加长型)
Long Concentric Reducer

3A

Size	AxB	L1	T
1/2"×1/4"	12.7×6.35	101.6	1.65
1/2"×3/8"	12.7×9.53	101.6	1.65
3/4"×3/8"	19.1×9.53	101.6	1.65
3/4"×1/2"	19.1×12.7	101.6	1.65
1"×1/2"	25.4×12.7	114.3	1.65
1"×3/8"	25.4×9.53	114.3	1.65
1"×3/4"	25.4×19.1	101.6	1.65
1.5"×1/2"	38.1×12.7	139.7	1.65
1.5"×3/4"	38.1×19.1	127	1.65
1.5"×1"	38.1×25.4	127	1.65
2"×1/2"	50.8×12.7	196.9	1.65
2"×3/4"	50.8×19.1	184.2	1.65
2"×1"	50.8×25.4	184.2	1.65
2"×1.5"	50.8×38.1	133.4	1.65
2.5"×1/2"	63.5×12.7	247.7	1.65
2.5"×3/4"	63.5×19.1	235	1.65
2.5"×1"	63.5×25.4	235	1.65
2.5"×1.5"	63.5×38.1	184.2	1.65
2.5"×2"	63.5×50.8	139.7	1.65
3"×1/2"	76.2×12.7	298.5	1.65
3"×1"	76.2×25.4	285.8	1.65
3"×1.5"	76.2×38.1	235	1.65
3"×2"	76.2×50.8	190.5	1.65
3"×2.5"	76.2×63.5	139.7	1.65
4"×1"	101.6×25.4	393.7	2.1
4"×1.5"	101.6×38.1	342.9	2.1
4"×2"	101.6×50.8	298.5	2.1
4"×2.5"	101.6×63.5	247.7	2.1
4"×3"	101.6×76.2	196.9	2.1
6"×4"	152.4×101.6	254	2.77

卡箍式大小头Clamped Reducer

3A

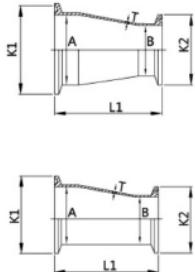

Size	AxB	K1xK2	L1	T
3/4"-1/2"	19×12.7	25.2×25.2	50.8	1.65×1.65
1"-1/2"	25.4×12.7	50.5×25.2	76.2	1.65×1.65
1"-3/4"	25.4×19	50.5×25.2	50.8	1.65×1.65
1 1/2"-3/4"	38.1×19	50.5×25.2	101.6	1.65×1.65
1 1/2"-1"	38.1×25.4	50.5×50.5	76.2	1.65×1.65
1 1/2"-1 1/2"	38.1×12.7	50.5×25.2	127	1.65×1.65
2"-1/2"	51×12.7	64×25.2	177.8	1.65×1.65
2"-3/4"	51×19	64×25.2	152.4	1.65×1.65
2"-1"	50.8×25.4	64×50.5	127	1.65×1.65
2"-1 1/2"	50.8×38.1	64×50.5	76.2	1.65×1.65
2 1/2"-1 1/2"	63.5×38.1	77.5×50.5	127	1.65×1.65
2 1/2"-2"	63.5×50.8	77.5×64	76.2	1.65×1.65
3"-1"	76.2×25.4	91×50.5	228.6	1.65×1.65
3"-1 1/2"	76.2×38.1	91×50.5	177.8	1.65×1.65
3"-2"	76.2×50.8	91×64	127	1.65×1.65
3"-2 1/2"	76.2×63.5	91×77.5	76.2	1.65×1.65
4"-1/2"	101.6×38.1	119×50.5	282.5	2×1.65
4"-2"	101.6×50.8	119×64	231.8	2×1.65
4"-2 1/2"	101.6×63.5	119×77.5	181	2×1.65
4"-3"	101.6×76.2	119×91	130.2	2×1.65
6"-3"	152.4×76.2	167×91	263.5	2.8×1.65
6"-4"	152.4×101.6	167×119	266.7	2.8×2.1

对焊“Y”型三通Butt Weld Y-Type Tee

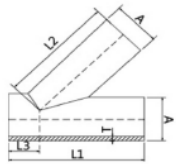

Size	A	L1	L2	L3	T
1/2"	12.7	152.4	127	25.4	1.65
3/4"	19.05	152.4	127	25.4	1.65
1"	25.4	152.4	127	25.4	1.65
1 1/2"	38.1	187.3	173.1	30.2	1.65
2"	50.8	222.2	180.9	41.3	1.65
2 1/2"	63.5	254	215.9	38.1	1.65
3"	76.2	273.1	225.4	47.6	1.65
4"	101.6	325.5	273.1	52.4	2.1
6"	152.4	419.1	317.5	101.6	2.8

3A

对焊“Y”型变径三通Butt Y-Type Reducer Tee

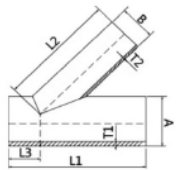

Size	AxB	L1	L2	L3	T1xT2
1 1/2"-1"	38.1x25.4	187.3	157.2	30.2	1.65x1.65
2"-1"	50.8x25.4	222.2	181	41.3	1.65x1.65
2"-1 1/2"	50.8x38.1	222.2	181	41.3	1.65x1.65
2 1/2"-1"	63.5x25.4	254	215.9	38.1	1.65x1.65
2 1/2"-1 1/2"	63.5x38.1	254	215.9	38.1	1.65x1.65
2 1/2"-2"	63.5x50.8	254	215.9	38.1	1.65x1.65
3"-1"	76.2x25.4	273.1	225.4	47.6	1.65x1.65
3"-1 1/2"	76.2x38.1	273.1	225.4	47.6	1.65x1.65
3"-2"	76.2x50.8	273.1	225.4	47.6	1.65x1.65
3"2 1/2"	76.2x63.5	273.1	225.4	47.6	1.65x1.65
4"-1"	101.6x25.4	325.5	273.1	52.4	2.1x1.65
4"-1 1/2"	101.6x38.1	325.5	273.1	52.4	2.1x1.65
4"-2"	101.6x50.8	274.7	273.1	52.4	2.1x1.65
4"-2 1/2"	101.6x63.5	325.5	273.1	52.4	2.1x1.65
4"-3"	101.6x76.2	325.5	273.1	52.4	2.1x1.65

3A

对焊“Y”型三通Butt Weld Y-Type Tee

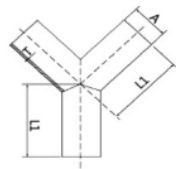

Size	A	L1	T
1/2"	12.7	50.8	1.65
3/4"	19.05	50.8	1.65
1"	25.4	76.2	1.65
1 1/2"	38.1	76.2	1.65
2"	50.8	101.6	1.65
2 1/2"	63.5	127	1.65
3"	76.2	152.4	1.65
4"	101.6	203.2	2.1
6"	152.4	203.2	2.8

3A

90°夹式双弯头90° Clamp Double Elbow

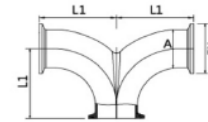

Size	A	K1	L1
1"	25.4	50.5	50.8
1 1/4"	31.75	50.5	69.85
1 1/2"	38.1	50.5	60.4
2"	50.8	64	88.9
2 1/2"	63.5	77.5	107.9
3"	76.2	91	127
4"	101.6	119	168.4

3A

对焊“R”型三通Butt Weld R-Type Tee

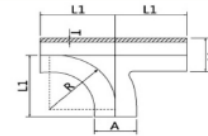

Size	A	R	L1	T
1"	25.4	38.1	65	1.65
1 1/2"	38.1	57.2	85	1.65
2"	50.8	76.2	110	1.65
2 1/2"	63.5	95.3	135	1.65
3"	76.2	114.3	155	1.65
4"	101.6	152.4	195	2.1

3A

焊接式弯头(45°) 45° Welded Elbow

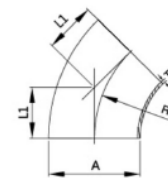

Size	A	R	L1	T
1"	25.4	33.5	13.9	1.2/1.5
1 1/4"	32	38	15.7	1.2/1.5
1 1/2"	38.1	48.5	20.1	1.2/1.5
2"	50.8	60.5	25.1	1.2/1.5
2 1/2"	63.5	83.5	34.6	2
3"	76.2	88.5	36.7	2
3 1/2"	89	103.5	42.9	2
4"	101.6	127	52.1	2

ISO/IDF

焊接式弯头 (90°) 90° Welded Elbow

ISO/IDF

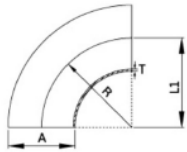

Size	A	R	L1	T
1"	25.4	33.5	33.5	1.2/1.5
1 1/4"	32	38	38	1.2/1.5
1 1/2"	38.1	48.5	48.5	1.2/1.5
2"	50.8	60.5	60.5	1.2/1.5
2 1/2"	63.5	83.5	83.5	2
3"	76.2	88.5	88.5	2
3 1/2"	89	103.5	103.5	2
4"	101.6	127	127	2
4 1/2"	114.3	152.4	152.4	2
5"	127	190.5	190.5	2.77
6"	152.4	228.6	228.6	2.77

卡箍式弯头 (45°) 45° Clamped Elbow

ISO/IDF

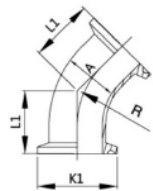

Size	A	R	L1	K1
1"	25.4	33.5	35.4	50.5
1 1/4"	31.8	38	37.2	50.5
1 1/2"	38.1	48.5	41.6	50.5
2"	50.8	60.5	46.6	64
2 1/2"	63.5	83.5	56.1	77.5
3"	76.2	88.5	58.2	91
3 1/2"	89	103.5	64.4	106
4"	101.6	127	72.3	119

卡箍式弯头 (90°) 90° Clamped Elbow

ISO/IDF

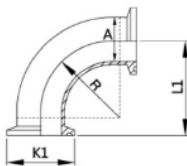

Size	A	R	L1	K1
1"	25.4	33.5	55	50.5
1 1/4"	31.8	38	59.5	50.5
1 1/2"	38.1	48.5	70	50.5
2"	50.8	60.5	82	64
2 1/2"	63.5	83.5	105	77.5
3"	76.2	88.5	110	91
3 1/2"	89	103.5	125	106
4"	101.6	127	148.5	119

焊接式三通 Welded Tee

ISO/IDF

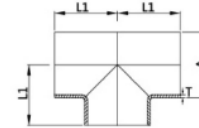

Size	A	L1	T
1"	25.4	33.5	1.2/1.5
1 1/4"	31.8	38.1	1.2/1.5
1 1/2"	38.1	48.5	1.2/1.5
2"	50.8	60.5	1.2/1.5
2 1/2"	63.5	83.5	2
3"	76.2	88.5	2
3 1/2"	89	103.5	2
4"	101.6	127	2

卡箍式三通 Clamped Tee

ISO/IDF

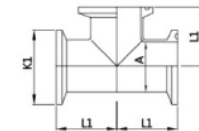

Size	A	L1	K1
1"	25.4	55	50.5
1 1/4"	31.8	59.5	50.5
1 1/2"	38.1	70	50.5
2"	50.8	82	64
2 1/2"	63.5	104.5	77.5
3"	76.2	109.5	91
3 1/2"	89	124.5	106
4"	101.6	148.5	119

焊接式四通 Welded Cross

ISO/IDF

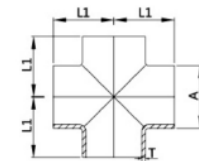

Size	A	L1	T
1"	25.4	33.5	1.2/1.5
1 1/4"	32	38	1.2/1.5
1 1/2"	38	48.5	1.2/1.5
2"	51	60.5	1.2/1.5
2 1/2"	63.5	83.5	2
3"	76.2	88.5	2
3 1/2"	89	103.5	2
4"	101.6	127	2

焊接式大小头Welded Reducer

ISO/IDF

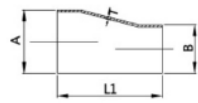
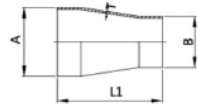

Size	AxB	L1	T
1"-3/4"	25.4×19	38	1.2/1.5×1.2/1.5
1 1/4"-1"	31.8×25.4	50	1.2/1.5×1.2/1.5
1 1/2"-1"	38.1×25.4	50	1.2/1.5×1.2/1.5
1 1/2"-1 1/4"	38.1×31.8	50	1.2/1.5×1.2/1.5
2"-1"	50.8×25.4	67	1.2/1.5×1.2/1.5
2"-1 1/4"	50.8×31.8	67	1.2/1.5×1.2/1.5
2"-1 1/2"	50.8×38.1	67	1.2/1.5×1.2/1.5
2 1/2"-1"	63.5×25.4	67	2×1.2/1.5
2 1/2"-1 1/2"	63.5×38.1	67	2×1.2/1.5
2 1/2"-2"	63.5×50.8	67	2×1.2/1.5
3"-1 1/2"	76.2×38.1	67	2×1.2/1.5
3"-2"	76.2×50.8	67	2×1.2/1.5
3"-2 1/2"	76.2×63.5	67	2×2
3 1/2"-2"	88.9×50.8	67	2×1.2/1.5
3 1/2"-2 1/2"	88.9×63.5	67	2×2
3 1/2"-3"	88.9×76.2	67	2×2
4"-2"	101.6×50.8	102	2×1.2/1.5
4"-2 1/2"	101.6×63.5	102	2×2
4"-3"	101.6×76.2	102	2×2
4"-3 1/2"	101.6×88.9	102	2×2

卡箍式大小头Clamped Reducer

ISO/IDF

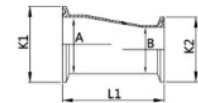
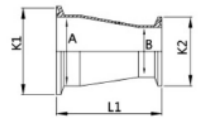

Size	AxB	K1xK2	L1
1"×3/4"	25.4×19	50.5×34	80
1 1/4"×1"	31.8×25.4	50.5×50.5	92
1 1/2"×1 1/4"	38.1×31.8	50.5×50.5	92
1 1/2"×1"	38.1×25.4	50.5×50.5	92
2"×1 1/2"	50.8×38.1	64×50.5	109
2"×1 1/4"	50.8×31.8	64×50.5	109
2"×1"	50.8×25.4	64×50.5	109
2 1/2"×2"	63.5×50.8	77.5×64	109
2 1/2"×1 1/2"	63.5×38.1	77.5×50.5	109
2 1/2"×1"	63.5×25.4	77.5×50.5	109
3"×2 1/2"	76.2×63.5	91×77.5	109
3"×2"	76.2×50.8	91×64	109
3"×1 1/2"	76.2×38.1	91×50.5	109
3 1/2"×3"	89×76.2	106×91	109
3 1/2"×2 1/2"	89×63.5	106×77.5	109
3 1/2"×2"	89×50.8	106×64	109
4"×3 1/2"	101.6×89	119×106	145
4"×3"	101.6×76.2	119×91	145
4"×2 1/2"	101.6×63.5	119×77.5	145
4"×2"	101.6×50.8	119×64	145

短型焊接式弯头 (45°) 45° Short Welded Elbow

BS

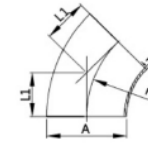

Size	A	R	L1	T
1"	25.4	38.1	15.8	1.65
1 1/2"	38.1	57.2	23.7	1.65
2"	50.8	76.2	31.8	1.65
2 1/2"	63.5	95.3	39.6	1.65
3"	76.2	114.3	47.5	1.65
4"	101.6	152.4	63.2	2.11

长型焊接式弯头 (45°) 45° Long Welded Elbow

BS

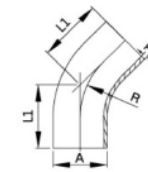

Size	A	R	L1	T
1"	25.4	38.1	30.2	1.65
1 1/2"	38.1	57.2	41.3	1.65
2"	50.8	76.2	58.7	1.65
2 1/2"	63.5	95.3	76.2	1.65
3"	76.2	114.3	93.7	1.65
4"	101.6	152.4	122.2	2.11

焊接式弯头 (90°) 90° Welded Elbow

BS

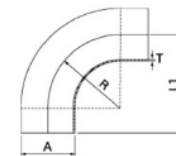

Size	A	R	L1	T
1"	25.4	38.1	43.5	1.65
1 1/4"	31.8	47.7	53.5	1.65
1 1/2"	38.1	57.2	63.5	1.65
2"	50.8	76.2	88.5	1.65
2 1/2"	63.5	95.3	113.5	1.65
3"	76.2	114.3	133.5	1.65
4"	101.6	152.4	173.5	2.11

长型焊接式弯头 (90°) 90° Long Welded Elbow

BS

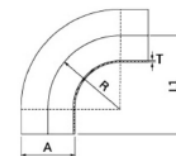

Size	A	R	L1	T
1/2"	12.7	19	45	1.65
3/4"	19	28.58	60	1.65
1"	25.4	38.1	65	1.65
1 1/4"	31.8	47.7	75	1.65
1 1/2"	38.1	57.2	85	1.65
2"	50.8	76.2	110	1.65
2 1/2"	63.5	95.3	135	1.65
3"	76.2	114.3	155	1.65
4"	101.6	152.4	195	12.11

卡箍式弯头 (90°) 90° Clamped Elbow

BS

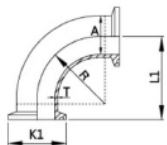

Size	A	R	L1	K1	T
1"	25.4	38.1	65	50.5	1.65
1 1/2"	38.1	57.2	85	50.5	1.65
2"	50.8	76.2	110	64	1.65
2 1/2"	63.5	95.3	135	77.5	1.65
3"	76.2	114.3	155	91	1.65
4"	101.6	152.4	195	119	2.11

卡箍式三通 Clamped Tee

BS

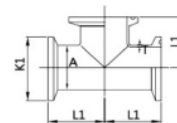

Size	A	L1	K1	T
1/2"	12.7	57.2	25.4	1.65
3/4"	19	60.3	25.4	1.65
1"	25.4	66.7	50.5	1.65
1 1/2"	38.1	73	50.5	1.65
2"	50.8	85.7	64	1.65
2 1/2"	63.5	92.1	77.5	1.65
3"	76.2	98.4	91	1.65
4"	101.6	120.7	119	2.11

短型焊接式三通 Short Welded Tee

BS

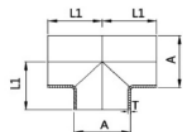

Size	A	L1	T
1"	25.4	43.5	1.65
1 1/4"	31.8	53.5	1.65
1 1/2"	38.1	63.5	1.65
2"	50.8	88.5	1.65
2 1/2"	63.5	113.5	1.65
3"	76.2	133.5	1.65
4"	101.6	173.5	2.11

焊接式四通 Welded Cross

BS

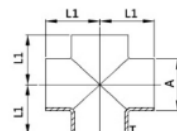

Size	A	L1	T
1"	25.4	65	1.65
1 1/2"	38.1	85	1.65
2"	50.8	110	1.65
2 1/2"	63.5	135	1.65
3"	76.2	155	1.65
4"	101.6	195	2.11

长型焊接式三通 Long Welded Tee

BS

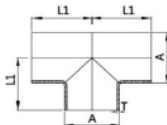

Size	A	L1	T
1"	25.4	65	1.65
1 1/2"	38.1	85	1.65
2"	50.8	110	1.65
2 1/2"	63.5	135	1.65
3"	76.2	155	1.65
4"	101.6	195	2.11

同心/偏心变径 Concentric/Eccentric Reducer

BS

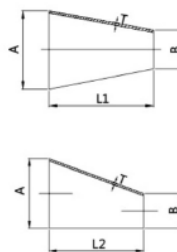

Size	AxB	L1	L2	T
1.5"-1"	38.1×25.4	29	35	1.6
2"-1"	50.8×25.4	53	54	1.6
2"-1.5"	50.8×38.1	41	36	1.6
2.5"-1"	63.5×25.4	82	76	1.6
2.5"-1.5"	63.5×38.1	64	66	1.6
2.5"-2"	63.5×50.8	40	35	1.6
3"-1"	76.2×25.4	110	112	1.6
3"-1.5"	76.2×38.1	81	38.1	1.6
3"-2"	76.2×50.8	55	50.8	1.6
3"-2.5"	76.2×63.5	41	63.5	1.6
4"-1.5"	101.6×38.1	135	38.1	2
4"-2"	101.6×50.8	106	50.8	2
4"-2.5"	101.6×63.5	76	63.5	2
4"-3"	101.6×76.2	53	76.2	2

长型焊接式弯头 (45°) 45° Long Welded Elbow

AS

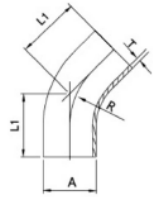

Size	A	R	L1	T
1/2"	12.7	19.05	37.9	1.6
3/4"	19.1	28.6	41.8	1.6
1"	25.4	38.1	45.8	1.6
1 1/4"	31.8	47.7	49.7	1.6
1 1/2"	38.1	57.2	53.7	1.6
2"	50.8	76.2	61.6	1.6
2 1/2"	63.5	95.3	69.5	1.6
3"	76.2	114.3	77.3	1.6
4"	101.6	152.4	92.8	2

平口焊接式三通 Short Welded Tee

AS

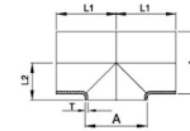

Size	A	L1	L2	T
1/2"	12.7	19.1	9.35	1.6
3/4"	19.1	28.6	12.55	1.6
1"	25.4	38.1	15.7	1.6
1 1/4"	31.8	47.7	18.9	1.6
1 1/2"	38.1	57	22.05	1.6
2"	50.8	76.2	28.4	1.6
2 1/2"	63.5	95	34.75	1.6
3"	76.2	114.2	41.1	1.6
4"	101.6	152.4	53.8	2

焊接式弯头 (90°) 90° Welded Elbow

AS

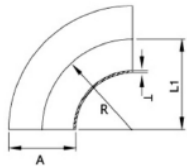

Size	A	R	L1	T
1/2"	12.7	19.05	19.1	1.6
3/4"	19.1	28.6	28.6	1.6
1"	25.4	38.1	38.1	1.6
1 1/4"	31.8	47.7	47.7	1.6
1 1/2"	38.1	57.2	57	1.6
2"	50.8	76.2	76.2	1.6
2 1/2"	63.5	95	95	1.6
3"	76.2	114.3	114.2	1.6
4"	101.6	152.4	152.4	2

焊接式三通 Welded Tee

AS

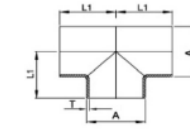

Size	A	L1	T
1/2"	12.7	19.1	1.6
3/4"	19.1	28.6	1.6
1"	25.4	38.1	1.6
1 1/4"	31.8	47.7	1.6
1 1/2"	38.1	57	1.6
2"	50.8	76.2	1.6
2 1/2"	63.5	95	1.6
3"	76.2	114.2	1.6
4"	101.6	152.4	2

长型焊接式弯头 (90°) 90° Long Welded Elbow

AS

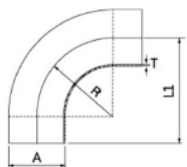

Size	A	R	L1	T
1/2"	12.7	19.05	49.1	1.6
3/4"	19.1	28.6	58.6	1.6
1"	25.4	38.1	68.1	1.6
1 1/4"	31.8	47.7	77.7	1.6
1 1/2"	38.1	57.2	87	1.6
2"	50.8	76.2	106.2	1.6
2 1/2"	63.5	95	125	1.6
3"	76.2	114.3	144.2	1.6
4"	101.6	152.4	182.4	2

长型焊接式三通 Long Welded Tee

AS

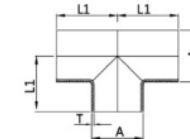

Size	A	L1	T
1/2"	12.7	49.1	1.6
3/4"	19.1	58.6	1.6
1"	25.4	68.1	1.6
1 1/4"	31.8	77.7	1.6
1 1/2"	38.1	87	1.6
2"	50.8	106.2	1.6
2 1/2"	63.5	125	1.6
3"	76.2	144.2	1.6
4"	101.6	182.4	2

变径焊接三通 Reducing Welded Tee

AS

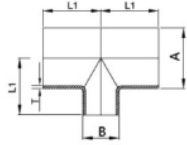

Size	AxB	L1	T
1 1/2"-1"	38.1×25.4	80	1.6
2"-1"	50.8×25.4	80	1.6
2"-1 1/2"	50.8×38.1	80	1.6
2 1/2"-1 1/2"	63.5×38.1	80	1.6
2 1/2"-2"	63.5×50.8	80	1.6
3"-1 1/2"	76.2×38.1	80	1.6
3"-2"	76.2×50.8	80	1.6
3"-2 1/2"	76.2×63.5	80	1.6
4"-2"	101.6×50.8	80	1.6
4"-2 1/2"	101.6×63.5	80	1.6
4"-3"	101.6×76.2	80	2

长型焊接四通 Long Welded Cross

AS

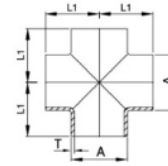

Size	A	L1	T
1/2"	12.7	49.1	1.6
3/4"	19.1	58.6	1.6
1"	25.4	68.1	1.6
1 1/4"	31.8	77.7	1.6
1 1/2"	38.1	87	1.6
2"	50.8	106.2	1.6
2 1/2"	63.5	125	1.6
3"	76.2	144.2	1.6
4"	101.6	182.4	2

平口变径焊接三通 Short Reducing Welded Tee

AS

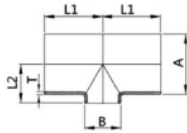

Size	AxB	L1	L2	T
1 1/2"-1"	38.1×25.4	80	22.05	1.6
2"-1"	50.8×25.4	80	28.4	1.6
2"-1 1/2"	50.8×38.1	80	28.4	1.6
2 1/2"-1 1/2"	63.5×38.1	80	34.75	1.6
2 1/2"-2"	63.5×50.8	80	34.75	1.6
3"-1 1/2"	76.2×38.1	80	41.1	1.6
3"-2"	76.2×50.8	80	41.1	1.6
3"-2 1/2"	76.2×63.5	80	41.1	1.6
4"-2"	101.6×50.8	80	53.8	1.6
4"-2 1/2"	101.6×63.5	80	53.8	1.6
4"-3"	101.6×76.2	80	53.8	2

焊接式大小 Welded Reducer

AS

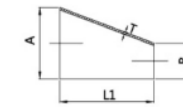
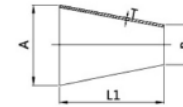

Size	AxB	L1	T
3/4"-1/2"	19.1×12.7	19.1	1.6
1-1/2"	25.4×12.7	25.4	1.6
1-3/4"	25.4×19.1	25.4	1.6
1 1/4"-3/4"	31.8×19.1	31.8	1.6
1 1/4"-1"	31.8×25.4	31.8	1.6
1 1/2"-3/4"	38.1×19.1	38.1	1.6
1 1/2"-1"	38.1×25.4	38.1	1.6
2"-1/2"	50.8×12.7	50.8	1.6
2"-3/4"	50.8×19.1	50.8	1.6
2"-1"	50.8×25.4	50.8	1.6
2"-1 1/4"	50.8×31.8	50.8	1.6
2"-1 1/2"	50.8×38.1	50.8	1.6
2 1/2"-1"	63.5×25.4	63.5	1.6
2 1/2"-1 1/4"	63.5×31.8	63.5	1.6
2 1/2"-1 1/2"	63.5×38.1	63.5	1.6
2 1/2"-2"	63.5×50.8	63.5	1.6
3"-1"	76.2×25.4	76.2	1.6
3"-1 1/4"	76.2×31.8	76.2	1.6
3"-1 1/2"	76.2×38.1	76.2	1.6
3"-2"	76.2×50.8	76.2	1.6
3"-2 1/2"	76.2×63.5	76.2	1.6
4"-1"	101.6×25.4	101.6	2
4"-1 1/4"	101.6×31.8	101.6	2
4"-1 1/2"	101.6×38.1	101.6	2
4"-2"	101.6×50.8	101.6	2
4"-2 1/2"	101.6×63.5	101.6	2
4"-3"	101.6×76.2	101.6	2

焊接式四通 Welded Cross

AS

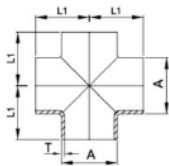

Size	A	L1	T
1/2"	12.7	19.1	1.6
3/4"	19.1	28.6	1.6
1"	25.4	38.1	1.6
1 1/4"	31.8	47.7	1.6
1 1/2"	38.1	57	1.6
2"	50.8	76.2	1.6
2 1/2"	63.5	95	1.6
3"	76.2	114.2	1.6
4"	101.6	152.4	2

长型焊接式弯头 (45°) 45° Long Welded Elbow

BPE

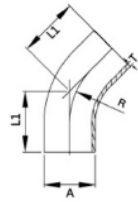

Size	A	R	L1	T
1/2"	12.7	19.1	57.2	1.65
3/4"	19.05	28.6	57.2	1.65
1"	25.4	38.1	57.2	1.65
1 1/2"	38.1	57.2	63.5	1.65
2"	50.8	76.2	76.2	1.65
2 1/2"	63.5	95.3	85.7	1.65
3"	76.2	114.3	92.1	1.65
4"	101.6	152.4	114.3	2.11
6"	152.4	288.6	158.8	2.77

卡箍式弯头 (45°) 45° Clamped Elbow

BPE

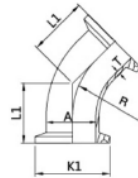

Size	A	R	L1	K1	T
1/2"	12.7	19.1	25.4	25.4	1.65
3/4"	19	28.6	25.4	25.4	1.65
1"	25.4	38.1	28.6	50.5	1.65
1 1/2"	38.1	57.2	36.5	50.5	1.65
2"	50.8	76.2	44.5	64	1.65
2 1/2"	63.5	95.3	52.4	77.5	1.65
3"	76.2	114.3	60.3	91	1.65
4"	101.6	152.4	79.4	119	2.11
6"	152.4	288.6	133.4	166.8	2.77

焊接式弯头 (90°) 90° Welded Elbow

BPE

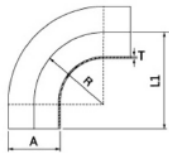

Size	A	R	L1	T
1/2"	12.7	19.1	76.2	1.65
3/4"	19.05	28.6	76.2	1.65
1"	25.4	38.1	76.2	1.65
1 1/2"	38.1	57.2	95.3	1.65
2"	50.8	76.2	120.7	1.65
2 1/2"	63.5	95.3	139.7	1.65
3"	76.2	114.3	158.8	1.65
4"	101.6	152.4	203.2	2.11
6"	152.4	228.6	292	2.77

卡箍式弯头 (90°) 90° Clamped Elbow

BPE

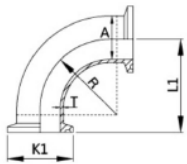

Size	A	R	L1	K1	T
1/2"	12.7	19	41.3	25.4	1.65
3/4"	19	28.6	41.3	25.4	1.65
1"	25.4	38.1	50.8	50.5	1.65
1 1/2"	38.1	57.2	69.9	50.5	1.65
2"	50.8	76.2	88.9	64	1.65
2 1/2"	63.5	95.3	108	77.5	1.65
3"	76.2	114.3	127	91	1.65
4"	101.6	152.4	168.3	119	2.11
6"	152.4	228.6	266.7	166.8	2.77

焊接式弯头 (180°) 180° Welded Elbow

BPE

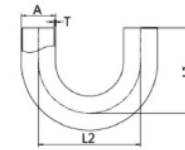

Size	A	L1	L2	T
1/2"	12.7	88.9	38.1	1.65
3/4"	19.05	88.9	57.2	1.65
1"	25.4	88.9	76.2	1.65
1 1/2"	38.1	127	114.3	1.65
2"	50.8	127	152.4	1.65
2 1/2"	63.5	146.1	190.5	1.65
3"	76.2	165.1	228.6	1.65
4"	101.6	215.9	304.8	2.1

焊接式弯头 (180°) 180° Welded Elbow

BPE

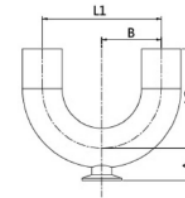

Size	A	B	L1	L2
3/4"×1/2"	25.4	57.15	57.2	95.25
1"×1/2"	25.58	57.15	76.2	95.25
1"×3/4"	25.58	57.15	76.2	95.25
1 1/2"×1/2"	34.93	76.2	114.3	114.3
1 1/2"×3/4"	34.93	76.2	114.3	114.3
1 1/2"×1"	34.93	76.2	114.3	114.3
2"×1/2"	41.28	76.2	152.4	127
2"×3/4"	41.28	76.2	152.4	127
2"×1"	41.28	76.2	152.4	127
2"×1 1/2"	41.28	76.2	152.4	127
2 1/2"×1/2"	47.63	95.25	190.5	146.05
2 1/2"×3/4"	47.63	95.25	190.5	146.05
2 1/2"×1"	47.63	95.25	190.5	146.05
2 1/2"×1 1/2"	47.63	95.25	190.5	146.05
2 1/2"×2"	47.63	95.25	190.5	146.05
3"×1/2"	53.98	114.3	228.6	165.1
3"×3/4"	53.98	114.3	228.6	165.1
3"×1"	53.98	114.3	228.6	165.1
3"×1 1/2"	53.98	114.3	228.6	165.1
3"×2"	53.95	114.3	228.6	165.1
3"×2 1/2"	53.95	114.3	228.6	165.1
4"×1/2"	66.68	152.4	304.8	215.9
4"×3/4"	66.68	152.4	304.8	215.9
4"×1"	66.68	152.4	304.8	215.9
4"×1 1/2"	66.68	152.4	304.8	215.9
4"×2"	66.68	152.4	304.8	215.9
4"×2 1/2"	66.68	152.4	304.8	215.9
4"×3"	66.68	152.4	304.8	215.9

焊接三通 Welded Tee

BPE

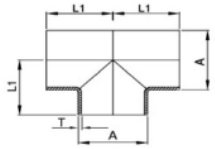

Size	A	L1	T
1/2"	12.7	47.6	1.65
3/4"	19.05	50.8	1.65
1"	25.4	54	1.65
1 1/2"	38.1	60.3	1.65
2"	50.8	73	1.65
2 1/2"	63.5	79.4	1.65
3"	76.2	85.7	1.65
4"	101.6	104.8	2.1

卡箍式四通 Clamped Cross

BPE

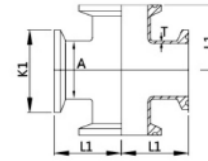

Size	A	L1	K1	T
1/2"	12.7	57.2	25.4	1.65
3/4"	19	60.3	25.4	1.65
1"	25.4	66.7	50.5	1.65
1 1/2"	38.1	73	50.5	1.65
2"	50.8	85.7	64	1.65
2 1/2"	63.5	92.1	77.5	1.65
3"	76.2	98.4	91	1.65
4"	101.6	120.7	119	2.11
6"	152.4	181	166.8	2.77

焊接三通 Welded Tee

BPE

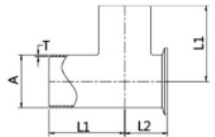

Size	A	L1	L2	T
1/2"	12.7	47.6	22.2	1.65
3/4"	19.05	50.8	19.05	1.65
1"	25.4	54	25.4	1.65
1 1/2"	38.1	60.3	38.1	1.65
2"	50.8	73	50.8	1.65
2 1/2"	63.5	79.4	63.5	1.65
3"	76.2	85.7	76.2	1.65
4"	101.6	104.8	101.6	2.1

焊接同心/偏心大小头 Welded Concentric Reducer

BPE

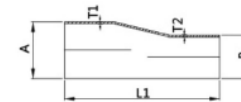
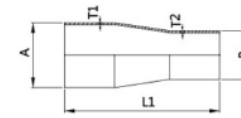

Size	AxB	L1	T1xT2
3/4"-1/2"	19.05x12.7	101.6	1.65x1.65
1"-1/2"	25.4x12.7	114.3	1.65x1.65
1"-3/4"	25.4x19.05	114.3	1.65x1.65
1 1/2"-1/2"	38.1x12.7	139.7	1.65x1.65
1 1/2"-3/4"	38.1x19.05	127	1.65x1.65
1 1/2"-1"	38.1x25.4	127	1.65x1.65
2"-1/2"	50.8x12.7	196.9	1.65x1.65
2"-3/4"	50.8x19.05	184.2	1.65x1.65
2"-1"	50.8x25.4	184.2	1.65x1.65
2"-1 1/2"	50.8x38.1	133.4	1.65x1.65
2 1/2"-1/2"	63.5x12.7	247.7	1.65x1.65
2 1/2"-3/4"	63.5x19.05	235	1.65x1.65
2 1/2"-1"	63.5x25.4	235	1.65x1.65
2 1/2"-1 1/2"	63.5x38.1	184.2	1.65x1.65
2 1/2"-2"	63.5x50.8	139.7	1.65x1.65
3"-1"	76.2x25.4	285.8	1.65x1.65
3"-1 1/2"	76.2x38.1	235	1.65x1.65
3"-2"	76.2x50.8	190.5	1.65x1.65
3"-2 1/2"	76.2x63.5	139.7	1.65x1.65
4"-1"	76.2x25.4	393.7	1.65x1.65
4"-1 1/2"	76.2x38.1	342.9	1.65x1.65
4"-2"	101.6x50.8	298.5	2.11x1.65
4"-2 1/2"	101.6x63.5	247.7	2.11x1.65
4"-3"	101.6x76.2	196.9	2.11x1.65
6"-4"	152.4x101.6	254	2.8x2.11

焊接四通 Welded Cross

BPE

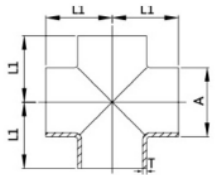

Size	A	L1	T
1/2"	12.7	47.6	1.65
3/4"	19.05	50.8	1.65
1"	25.4	54	1.65
1 1/2"	38.1	60.3	1.65
2"	50.8	73	1.65
2 1/2"	63.5	79.4	1.65
3"	76.2	85.7	1.65
4"	101.6	104.8	2.11
6"	152.4	142.9	2.77

High purity fittings
JIS pipe type

弯头 (90°) 90° Elbow

JIS

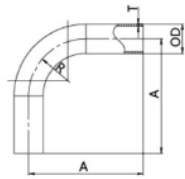

Size	OD	T	R	A
8A	13.8	1.2	25.4	55
10A	17.3	1.2	25.4	62
15A	21.7	1.65	38.1	75
20A	27.2	1.65	38.1	75
25A	34	1.65	38.1	75
32A	42.7	1.65	47.6	94
40A	48.6	1.65	57.2	104
50A	60.5	1.65	76.2	123
65A	76.3	2.1	95.3	147
80A	89.1	2.1	114.3	166
100A	114.3	2.1	152.4	204

弯头 (45°) 45° Elbow

JIS

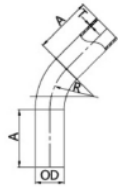

Size	OD	T	R	A
8A	13.8	1.2	25.4	40
10A	17.3	1.2	25.4	47
15A	21.7	1.65	38.1	52
20A	27.2	1.65	38.1	52
25A	34	1.65	38.1	52
32A	42.7	1.65	47.6	66
40A	48.6	1.65	57.2	70
50A	60.5	1.65	76.2	78
65A	76.3	2.1	95.3	91
80A	89.1	2.1	114.3	99
100A	114.3	2.1	152.4	115

等径三通 Equal Tee

JIS

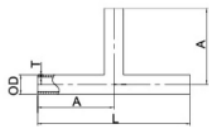

Size	OD	T	A	L
8A	13.8	1.2	42	84
10A	17.3	1.2	49	98
15A	21.7	1.65	59	118
20A	27.2	1.65	65	130
25A	34	1.65	68	136
32A	42.7	1.65	88	176
40A	48.6	1.65	95	190
50A	60.5	1.65	102	204
65A	76.3	2.1	121	242
80A	89.1	2.1	130	206
100A	114.3	2.1	145	290

High purity fittings
JIS pipe type

焊接式三通 Welded Tee

JIS

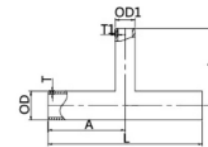

Size	OD	T	OD1	L1	A	B
10A×8A	17.3	1.2	13.8	1.2	47	44
15A×8A	21.7	1.65	13.8	1.2	47	44
15A×10A	21.7	1.65	17.3	1.2	52	52
20A×8A	27.2	1.65	13.8	1.2	47	47
20A×10A	27.2	1.65	17.3	1.2	55	55
20A×15A	27.2	1.65	21.7	1.65	55	55
25A×8A	34	1.65	13.8	1.2	47	50
25A×10A	34	1.65	17.3	1.2	59	59
25A×15A	34	1.65	21.7	1.65	59	59
25A×20A	34	1.65	27.2	1.65	59	59
32A×8A	42.7	1.65	13.8	1.2	57	54
32A×10A	42.7	1.65	17.3	1.2	68	62
32A×15A	42.7	1.65	21.7	1.65	68	62
32A×20A	42.7	1.65	27.2	1.65	68	62
32A×25A	42.7	1.65	34	1.65	68	62
40A×8A	48.6	1.65	13.8	1.2	57	57
40A×10A	48.6	1.65	17.3	1.2	68	65
40A×15A	48.6	1.65	21.7	1.65	68	65
40A×20A	48.6	1.65	27.2	1.65	68	65
40A×25A	48.6	1.65	34	1.65	68	65
40A×32A	48.6	1.65	42.7	1.65	77	77
50A×8A	60.5	1.65	13.8	1.2	57	63
50A×10A	60.5	1.65	17.3	1.2	68	71
50A×15A	60.5	1.65	21.7	1.65	68	71
50A×20A	60.5	1.65	27.2	1.65	68	71
50A×25A	60.5	1.65	34	1.65	68	71
50A×32A	60.5	1.65	42.7	1.65	83	83
50A×40A	60.5	1.65	48.6	1.65	83	83
65A×15A	76.3	2.1	21.7	1.65	72	79
65A×20A	76.3	2.1	27.2	1.65	72	79
65A×25A	76.3	2.1	34	1.65	72	79
65A×32A	76.3	2.1	42.7	1.65	88	90
65A×40A	76.3	2.1	48.6	1.65	88	90
65A×50A	76.3	2.1	60.5	1.65	88	90
80A×15A	89.1	2.1	21.7	1.65	72	85
80A×20A	89.1	2.1	27.2	1.65	72	85
80A×25A	89.1	2.1	34	1.65	72	85
80A×32A	89.1	2.1	42.7	1.65	88	96
80A×40A	89.1	2.1	48.6	1.65	88	96
80A×50A	89.1	2.1	60.5	1.65	88	96
80A×65A	89.1	2.1	76.3	2.1	103	103
100A×15A	114.3	2.1	21.7	1.65	72	98
100A×20A	114.3	2.1	27.3	1.65	72	98
100A×25A	114.3	2.1	34	1.65	72	98
100A×32A	114.3	2.1	42.7	1.65	88	109
100A×40A	114.3	2.1	48.6	1.65	88	109
100A×50A	114.3	2.1	60.5	1.65	88	109
100A×65A	114.3	2.1	76.3	2.1	116	116
100A×80A	114.3	2.1	89.1	2.1	116	116

High purity fittings
JIS pipe type

焊接同心大小头 Welded Concentric Reduce

JIS

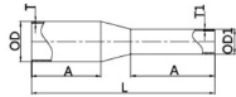

Size	OD	T	OD1	L1	A	B
10A×8A	17.3	1.2	13.8	1.2	36	90
15A×8A	21.7	1.65	13.8	1.2	36	100
15A×10A	21.7	1.65	17.3	1.2	36	100
20A×8A	27.2	1.65	13.8	1.2	36	105
20A×10A	27.2	1.65	17.3	1.2	36	105
20A×15A	27.2	1.65	21.7	1.65	36	105
25A×8A	34	1.65	13.8	1.2	36	120
25A×10A	34	1.65	17.3	1.2	36	120
25A×15A	34	1.65	21.7	1.65	36	120
25A×20A	34	1.65	27.2	1.65	36	120
32A×8A	42.7	1.65	13.8	1.2	46	125
32A×10A	42.7	1.65	17.3	1.2	46	125
32A×15A	42.7	1.65	21.7	1.65	46	125
32A×20A	42.7	1.65	27.2	1.65	46	125
32A×25A	42.7	1.65	34	1.65	46	125
40A×8A	48.6	1.65	13.8	1.2	46	130
40A×10A	48.6	1.65	17.3	1.2	46	130
40A×15A	48.6	1.65	21.7	1.65	46	130
40A×20A	48.6	1.65	27.2	1.65	46	130
40A×25A	48.6	1.65	34	1.65	46	130
40A×32A	48.6	1.65	42.7	1.65	46	130
50A×8A	60.5	1.65	13.8	1.2	46	140
50A×10A	60.5	1.65	17.3	1.2	46	140
50A×15A	60.5	1.65	21.7	1.65	46	140
50A×20A	60.5	1.65	27.2	1.65	46	140
50A×25A	60.5	1.65	34	1.65	46	140
50A×32A	60.5	1.65	42.7	1.65	46	140
50A×40A	60.5	1.65	48.6	1.65	46	140
65A×15A	76.3	2.1	21.7	1.65	51	165
65A×20A	76.3	2.1	27.2	1.65	51	165
65A×25A	76.3	2.1	34	1.65	51	165
65A×32A	76.3	2.1	42.7	1.65	51	165
65A×40A	76.3	2.1	48.6	1.65	51	165

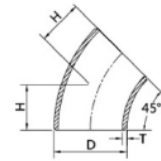

45°弯头45°Elbow

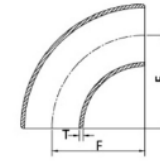

90°弯头90°Elbow

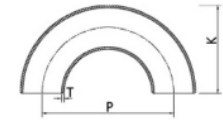

180°弯头180°Return

对焊弯头GB12459-90、GB/T13401
Butt-Welding Elbow And Returns

公称口径 Nominal pipe size DN	端部外径 at bevel D		中心至端面 Center to end			中心至中心 Center to center		背面至端面 Back to faces	
	A系列 Series A	B系列 Series B	45°弯头 Elbow	90°弯头 Elbow		180°弯头 Return		180°弯头 Return	
			H	F		P		K	
			长半径 Long radius	长半径 Long radius	短半径 Short radius	长半径 Long radius	短半径 Short radius	长半径 Long radius	短半径 Short radius
15	21.3	18	16	38	-	76	-	48	-
20	26.9	25	16	38	-	76	-	51	-
25	33.7	32	16	38	25	76	51	56	41
32	42.4	38	20	48	32	95	64	70	52
40	48.3	45	24	57	38	114	76	83	62
50	60.3	57	32	76	51	152	102	106	81
65	76.1 (73)	76	40	95	64	191	127	132	100
80	88.9	89	47	114	76	229	152	159	121
90	101.6	-	55	133	89	267	178	184	140
100	114.3	108	63	152	102	305	203	210	159
125	139.7	133	79	190	127	381	254	262	197
150	168.3	159	95	229	152	457	305	313	237
200	219.1	219	126	305	203	610	406	414	313
250	273	273	158	381	254	762	508	518	391
300	323.9	325	189	457	305	914	610	619	467
350	335.6	337	221	533	356	1067	711	711	533
400	406.4	426	253	610	406	1219	813	813	610
450	457.2	478	284	686	457	1372	914	914	686
500	508	529	316	762	508	1524	1016	1016	762
550	559	-	347	838	559				
600	610	630	379	914	610				
650	660	-	410	991	660				
700	711	720	442	1067	711				
750	762	-	473	1143	762				
800	813	820	505	1219	813				
850	864	-	537	1295	864				
900	914	920	568	1372	914				
950	965	-	600	1448	965				
1000	1016	1020	631	1524	1016				
1050	1067	-	663	1600	1067				
1100	1118	1120	694	1676	1118				
1150	1168	-	726	1753	1168				
1200	1220	1220	758	1829	1219				

注:(1)尽可能不采用括号内的数值。

(2)优先选用A系列。

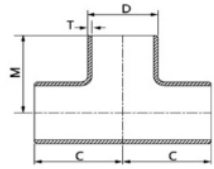

等径三通Straight Tee

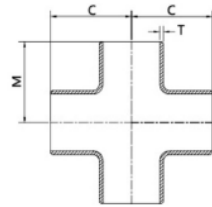

等径四通Straight Cross

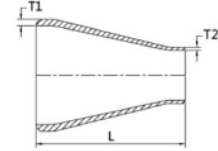

同心异径管Concentric Reducer

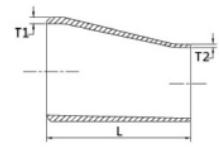

偏心异径管Eccentric Reducer

对焊等径、三通、四通GB12459、GB/T13401
Butt-Welding Straight Tees And Crosses

公称通径 Nominal pipe size DN	端部外径 Outside diameter at bevel D		中心至端面 Center to end	
	D		C	M
	A系列 Series A	B系列 Series B		
15	21.3	18	25	
20	26.9	25	29	
25	33.7	32	38	
32	42.4	38	48	
40	48.3	45	57	
50	60.3	57	64	
65	76.1(73)	76	76	
80	88.9	89	86	
90	101.6	-	95	
100	114.3	108	105	
125	139.7	133	124	
150	168.3	159	143	
200	219.1	219	178	
250	273	273	216	
300	323.9	325	254	
350	335.6	337	279	
400	406.4	426	305	

公称通径 Nominal pipe size DN	端部外径 Outside diameter at bevel D		中心至端面 Center to end	
	D		C	M
	A系列 Series A	B系列 Series B		
450	457.2	478	343	
500	508	529	381	
550	559	-	419	
600	610	630	432	
650	660	-	495	
700	711	720	521	
750	762	-	559	
800	813	820	597	
850	864	-	635	
900	914	920	673	
950	965	-	711	
1000	1016	1020	749	
1050	1067	-	762	711
1100	1118	1120	813	762
1150	1168	-	851	800
1200	1220	1220	889	838

对焊同心、偏心异径管GB12459、GB/T13401
Butt-Welding Concentric & Eccentric Reducers

公称通径 Nominal pipe size DN	端部外径 Outside diameter at bevel		端部外径 Outside diameter at bevel		长度 End to end L
	D1		D2		
	A系列 Series A	B系列 Series B	A系列 Series A	B系列 Series B	
20×15	26.9	25	21.3	18	38
25×20	26.9	25	26.9	25	
25×15	33.7	32	21.3	18	51
32×25			33.7	32	
32×20	42.4	38	26.9	25	51
32×15			21.3	18	
40×32			42.4	38	
40×25	48.3	45	33.7	32	64
40×20			26.9	25	
40×15			21.3	18	
50×40			48.3	45	
50×32			42.4	38	
50×25	60.3	57	33.7	32	76
50×20			26.9	25	
65×50			60.3	57	
65×40	76.1(73)	76	48.3	45	89
65×32			42.4	38	
65×25			33.7	32	
80×65			76.1(73)	76	
80×50			60.3	57	
80×40	88.9	89	48.3	45	89
80×32			42.4	38	
90×80			88.9	-	
90×65			76.1(73)	-	
90×50	101.6	-	60.3	-	102
90×40			48.3	-	
90×32			42.4	-	
100×90			101.6	-	
100×80			88.9	89	
100×65	114.3	108	76.1(73)	76	102
100×50			60.3	57	
100×40			48.3	45	
125×100			133	114.3	108
125×90	139.7	-	101.6	-	127
125×80			133	88.9	89

公称通径 Nominal pipe size DN	端部外径 Outside diameter at bevel		端部外径 Outside diameter at bevel		长度 End to end L
	D1		D2		
	A系列 Series A	B系列 Series B	A系列 Series A	B系列 Series B	
125×65			76.1(73)	76	
125×50	139.7	133	60.3	57	127
150×125			159	139.7	133
150×100			159	114.3	108
150×90	168.3	-	101.6	-	140
150×80			159	88.9	89
150×65			159	76.1(73)	76
200×150			219	168.3	159
200×125			219	139.7	133
200×100	219.1	219	114.3	108	152
200×90			-	101.6	-
250×200			219.1	219	
250×150			168.3	159	
250×125	273	273	139.7	133	178
250×100			114.3	108	
300×250			273	273	
300×200			219.1	219	
300×150	323.9	325	168.3	159	203
300×125			139.7	133	
350×300			323.9	325	
350×250			273	273	
350×200	355.6	377	219.1	219	330
350×150			168.3	159	
400×350			355.6	377	
400×300			323.9	325	
400×250	405.4	426	273	273	356
400×200			219.1	219	
450×400			406.4	426	
450×350			355.6	377	
450×300	457.2	478	323.9	325	381
450×250			273	273	
500×450			457.2	478	
500×400			406.4	426	
500×350	508	529	355.6	377	508
500×300			323.9	325	

各种标准钢管系列Stainless Steel Pipe Series

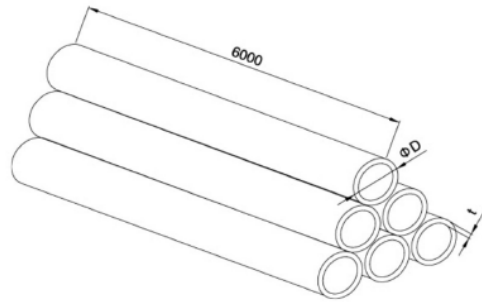

ISO 2037			SMS			3A			IDF		
Size	D	t	Size	t	t	Size	D	t	Size	D	t
19	19.0	1.5	25	1.25	1.5	1/2"	12.7	1.65	1.0"	25.4	1.5
25	25.4	1.5	32	1.25	1.5	3/4"	19.1	1.65	1 1/4"	32.0	1.5
32	32.0	1.5	38	1.25	1.5	1.0"	25.4	1.65	1 1/2"	38.1	1.5
38	38.1	1.5	51	1.25	1.5	1.5"	38.1	1.65	2.0"	50.8	1.5
45	45.0	2.0	63	1.50	2.0	2.0"	50.8	1.65	2 1/2"	63.5	2.0
48	48.0	1.5	76	1.60	2.0	2.5"	63.5	1.65	3.0"	76.2	2.0
51	50.8	1.5	89	2.0	2.0	3.0"	76.2	1.65	3 1/2"	89.0	2.0
57	57.0	2.0	101.6	2.0	2.0	4.0"	101.6	2.10	4.0"	101.6	2.0
63	63.5	2.0				6.0"	152.4	2.80	4 1/4"	108.0	2.0
76	76.2	2.0				8.0"	203.2	2.80			
80	85.0	2.0				10.0"	254.0	3.40			
89	89.0	2.0				12.0"	305.0	3.40			
102	101.6	2.0									
108	108.0	2.0									
133	133.0	3.0									
159	159.0	3.0									
219	219.0	4.0									

DIN11850/11851				BS4825			ISO 1127			JIS G3447		
Size	Dxt	Dxt	Dxt	Size	t	t	Size	OD	ID	Size	D	t
DN10	12×1.0	13×1.5	14×1.5	12×1.5	12.7	1.2	26.9	26.9	23.7	1.0"	25.4	1.2
DN15	18×1.0	19×1.5	20×1.5	18×1.5	15.88	1.2	33.7	33.7	29.7	1.25"	31.8	1.2
DN20	22×1.0	23×1.5	24×1.5	22×1.5	19.05	1.2	42.4	42.4	38.4	1.5"	38.1	1.2
DN25	28×1.0	29×1.5	30×1.5	28×1.5	25.4	1.2	48.3	48.3	44.3	2.0"	50.8	1.5
DN32	34×1.0	35×1.5	36×1.5	34×1.5	38.1	1.2	60.3	60.3	56.3	2.5"	63.5	2.0
DN40	40×1.0	41×1.5	42×2.0	40×1.5	50.8	1.2	76.2	76.2	72.2	3.0"	76.2	2.0
DN50	52×1.0	53×1.5	54×2.0	52×1.5	63.5	1.6	88.9	88.9	84.9	3.5"	88.9	2.0
DN65	70×2.0	70×2.0	70×2.0	70×2.0	76.2	1.6	114.3	114.3	110.0	4.0"	101.6	2.0
DN80	85×2.0	85×2.0	85×2.0	85×2.0	101.6	2.0	139.7	139.7	135.7	4.5"	114.3	3.0
DN100	104×2.0	104×2.0	104×2.0	104×2.0	114.3	2.0	168.3	168.3	161.5	5.5"	139.7	3.0
DN125	129×2.0	129×2.0	129×2.0	129×2.0	139.7	2.0	219.1	219.1	213.9	6.5"	165.1	3.0
DN150	154×2.0	154×2.0	154×2.0	154×2.0	168.3	2.6	219.1	219.1	213.9	6.5"	165.1	3.0
Series1	Series2	Series3	Recommended series	219.1	2.6	2.6						

各国不锈钢牌号 Stainless Steel Standards of Different Countries

中国 (China)	欧盟 (Europa)	美国 (U.S.A)	美国 (U.S.A)	英国 (U.K.)	德国 (Germany)	日本 (Japan)
GB 0Cr18Ni9 (06Cr19Ni10)	EN X5CrNi18-10	AlSI 304	ASTM Tp304	BSI 304 S 15 304 S 16	DIN 1.4301	JIS SUS304
00Cr19Ni10 (022Cr19Ni10)	X2CrNi19-11	304L	TP304L	304 S 11	1.4306	SUS304L
0Cr17Ni12Mo2 (06Cr17Ni12Mo2)	X5CrNiMo17-2-2	316	TP316	316 S 31	1.4401	SUS316
00Cr17Ni14Mo2 (022Cr17Ni12Mo2)	X2CrNiMo17-2-2	316L	TP316L	316 S 11	1.4404	SUS316L

化学成分与力学性能 Chemical Composition and Mechanics Property

中国 (GB)	钢种	碳 ≤ C	硅 ≤ Si	锰 ≤ Mn	磷 ≤ P	硫 ≤ S	铬 Cr	钼 Mo	镍 Ni	力学性能			
										屈服强度 σ ₂ (Mpa) ≥	抗拉强度 ob(Mpa) ≥	延伸率 δ ₅ %	硬度 HB ≤
304	0.07	1.0	2.0	0.035	0.030	18.0-20.0	/	8.0-11	205	520	40	187	
304L	0.03	1.0	2.0	0.035	0.030	18.0-20.0	/	8.0-12	177	480	40	187	
316	0.08	1.0	2.0	0.035	0.030	16.0-18.5	2.0-3.0	10-14	205	250	40	187	
316L	0.03	1.0	2.0	0.035	0.030	16.0-18.0	2.0-3.0	12-15	177	480	40	187	

美国 (ASTM)	钢种	碳 ≤ C	硅 ≤ Si	锰 ≤ Mn	磷 ≤ P	硫 ≤ S	铬 Cr	钼 Mo	镍 Ni	力学性能			
										屈服强度 σ ₂ (Mpa) ≥	抗拉强度 ob(Mpa) ≥	延伸率 δ ₅ %	硬度 HB ≤
Tp304	0.08	0.75	2.0	0.040	0.030	18.0-20.0	/	8.0-11	205	515	35	187	
TP304L	0.035	0.75	2.0	0.040	0.030	18.0-20.0	/	8.0-13	170	485	35	187	
TP316	0.08	0.75	2.0	0.040	0.030	16.0-18.0	2.0-2.5	10-14	205	515	35	187	
TP316L	0.035	0.75	2.0	0.040	0.030	16.0-18.0	2.0-2.5	12-15	170	485	35	187	

日本 (JIS)	钢种	碳 ≤ C	硅 ≤ Si	锰 ≤ Mn	磷 ≤ P	硫 ≤ S	铬 Cr	钼 Mo	镍 Ni	力学性能			
										屈服强度 σ ₂ (Mpa) ≥	抗拉强度 ob(Mpa) ≥	延伸率 δ ₅ %	硬度 HB ≤
304	0.08	1.0	2.0	0.040	0.030	18.0-20.0	/	8.0-11	206	520	35	187	
304L	0.03	1.0	2.0	0.040	0.030	18.0-20.0	/	9.0-13	177	481	35	187	
316	0.08	1.0	2.0	0.040	0.030	16.0-18.0	2.0-3.0	10-14	206	520	35	187	
316L	0.03	1.0	2.0	0.040	0.030	16.0-18.0	2.0-3.0	12-16	177	481	35	187	

美国 (AISI) 英国 (BSI) 德国 (DIN) 欧盟 (EN)	钢种	碳 ≤ C	硅 ≤ Si	锰 ≤ Mn	磷 ≤ P	硫 ≤ S	铬 Cr	钼 Mo	镍 Ni	力学性能			
										屈服强度 σ ₂ (Mpa) ≥	抗拉强度 ob(Mpa) ≥	延伸率 δ ₅ %	硬度 HB ≤
304	0.07	1.0	2.0	0.045	0.015	17.0-18.0	/	8.0-10	205	520	40	187	
304L	0.03	1.0	2.0	0.045	0.015	17.0-18.0	/	8.0-10	180	480	40	187	
316	0.08	1.0	2.0	0.045	0.015	16.5-18.0	2.0-2.5	10-13	205	520	40	187	
316L	0.03	1.0	2.0	0.045	0.015	16.5-18.0	2.0-2.5	10-13	180	480	40	187	



Sanitary Clamp Unions

卫生级卡箍/由任/接头



卡箍
Clamp

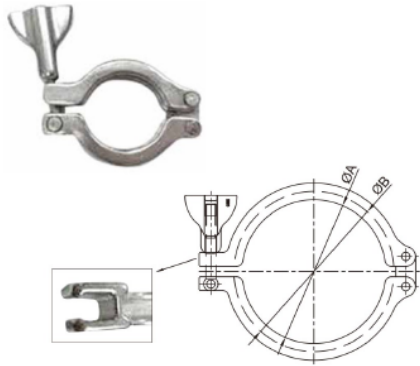
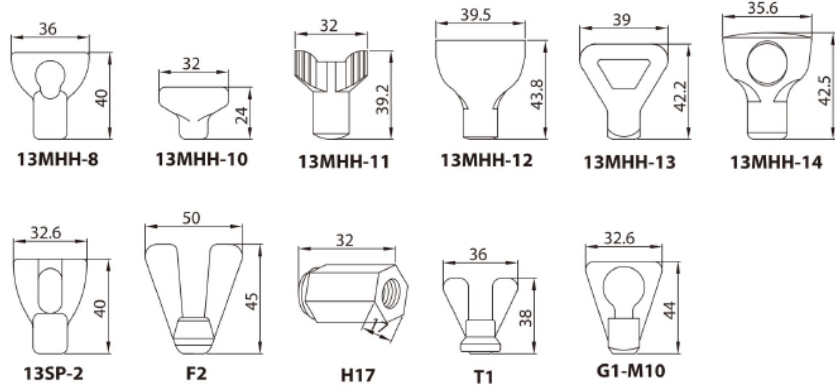

13SC安全卡箍
13SC SAFETY CLAMPS

Imperial	ØA	ØB	DN	ØA	ØB
1/2"~3/4"	20.58	28.34	DN10-DN20	27.2	37
1.0"~1.5"	41.02	53.52	DN25-DN40	44.5	54.5
2.0"	54.54	67.04	DN50	57	68
2.5"	68.02	80.52	DN65	84	95
3.0"	81.52	94.02	DN80	99	110
4.0"	109.54	122.04	DN100	112	123
6.0"	157.6	175.1	DN115	123	134
8.0"	207.4	225.9	DN125	144	159
			DN150	172	187
			DN200	222.5	237.5
			DN250	257	272
			DN300	308	323

1/2"~3/4"

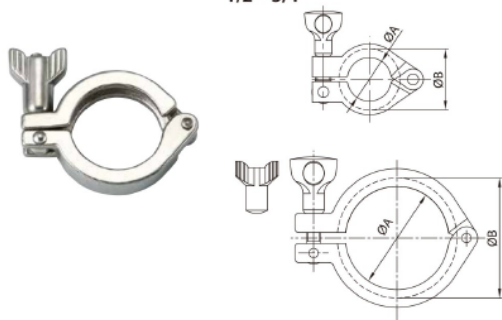

13MHH重型单销卡箍
13MHH HEAVY DUTY SINGLE PIN CLAMP

SIZE	ØA	ØB
1/2"~3/4"	21.2	28.2
A37	27.8	37
1"~1.5"	42	53.6
2"	55.4	67
2.5"	69	80.6
3"	82.6	94.2
3.5"	97.6	109.2
4"	110.6	122.2
4.5"	121.6	133.2
6"	156.2	170.4
8"	205.8	220

卡箍
Clamp

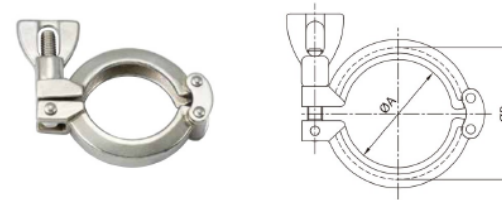

13SF 重型双销卡箍
13SF HEAVY DUTY DOUBLE PIN CLAMP

SIZE	ØA	ØB
1/2"~3/4"	20	28
A37	27.5	42.9
1"~1.5"	45	53.6
2"	59	72
2.5"	67	84
3"	85	98
4"	114	127
6"	158	178
8"	210	227
10"	262	278

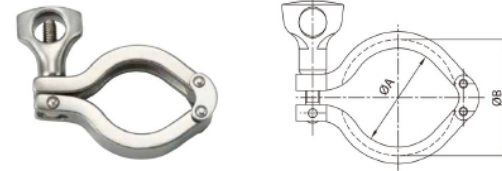

13MHHM双销卡箍
13MHHM DOUBLE PIN CLAMP

SIZE	ØA	ØB
1/2"~3/4"	20	28
A37	28	38
1"~1.5"	43.6	53.6
2"	57	67
2.5"	70.6	80.6
3"	84	94
4"	112	122
6"	155	170
8"	205	220.8

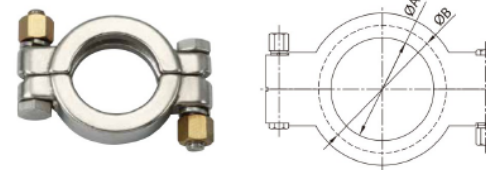

13MHP高压卡箍
13MHP HIGH PRESSURE BOLTED CLAMP

SIZE	ØA	ØB
1/2"~3/4"	20	28
1"~1.5"	43.32	52
2"	56.44	65.5
2.5"	69.54	79
3"	77.56	92.5
4"	108.86	120.5
6"	158	170
6.5"	173	186.2
8"	224	249
10"	258.2	276.8
12"	309	327.6

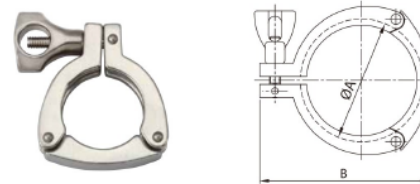

13MHS三片式卡箍
13MHS 3PIECE CLAMP

SIZE	ØA	B
1"~1.5"	54	80
2"	67.5	94
2.5"	80.9	109
3"	84.4	126
4"	122.4	154

卡箍
Clamp

卫生级卡箍接头
Sanitary Ferrule

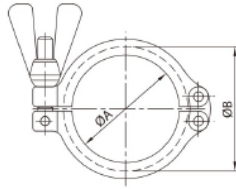

13CS双销卡箍
13CS DOUBLE PIN CLAMP

SIZE	ØA	ØB
1/2"~3/4"	20.58	28.34
DN10-20	27.2	37
1.5"	41.02	53.52
DN25-40	44.5	54.5
2.0"	54.54	67.04
DN50	57	68
2.5"	68.02	80.52
3.0"	81.52	94.02
DN65	84	95
DN80	99	110
4.0"	109.54	122.04
DN100	112	123
DN115	123	134
DN125	144	159
6.0"	157.6	175.1
DN150	172	187
8.0"	207.4	225.9
DN200	222.5	237.5
DN250	257	272
DN300	308	323

3A-1/2"~3/4"
SMS-DN15~DN20
DIN-DN6~DN8
DIN(ISO)-DN6~DN10

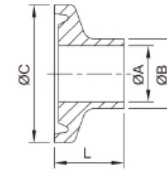

3A-1.0"~12"
SMS-DN25~DN100
DIN-DN10~DN100
DIN(ISO)-DN15~DN200

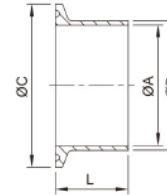

3A/SMS 快装接头
3A/SMS Welding Ferrule

SIZE	ØA	ØB	ØC	14WMP 14MMP 14AMP		
				L	L	L
1/4"	3.9	6.35	25	12.7	21.5	28.6
1/2"	9.4	12.7	25	12.7	21.5	28.6
DN15	9.7	12.7	25.4	12.7	21.5	28.6
3/4"	15.75	19.05	25	12.7	21.5	28.6
DN20	15.95	19.05	25.4	12.7	21.5	28.6
1"	22.1	25.4	50.5	12.7	21.5	28.6
DN25	22.5	25	50.5	12.7	21.5	28.6
1.25"	28.45	31.75	50.5	12.7	21.5	28.6
1.5"	34.8	38.1	50.5	12.7	21.5	28.6
DN38	35.5	38	50.5	12.7	21.5	28.6
2.0"	47.5	50.8	64	12.7	21.5	28.6
DN50	48.5	51	64	12.7	21.5	28.6
2.5"	60.2	63.5	77.5	12.7	21.5	28.6
DN63	60.3	63.5	77.5	12.7	21.5	28.6
DN76	72.9	76.1	91	12.7	21.5	28.6
3.0"	72.9	76.2	91	12.7	21.5	28.6
DN104	100	104	119	15.8	21.5	28.6
4.0"	97.4	101.6	119	15.8	21.5	28.6
5.0"	121.46	127	144.45	15.8	21.5	28.6 or 38.1
6.0"	146.86	152.4	166.87	—	21.5	28.6 or 38.1
8.0"	197.66	203.2	217.67	—	21.5	28.6 or 38.1
10"	247.2	254	268.47	—	21.5	28.6 or 38.1
12"	298	304.8	319.27	—	21.5	28.6 or 38.1

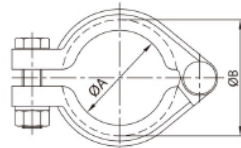

13IU 螺栓式卡箍
13IU BOLTED CLAMP

SIZE	ØA	ØB
1"~1.5"	45	55
2.0"	63	73
2.5"	74	89
3.0"	87	102
4.0"	111	128

DIN(ISO) 快装接头
DIN(ISO) Ferrule

SIZE	ØA	ØB	ØC	L
DN6	7	10.2	25	12.7
DN8	10.3	13.5	25	12.7
DN10	14	17.2	25	12.7
DN15	18.1	21.3	50.5	21.5
DN20	23.7	26.9	50.5	21.5
DN25	29.7	33.7	50.5	21.5
DN32	38.4	42.4	64	21.5
DN40	44.3	48.3	64	21.5
DN50	56.3	60.3	77.5	28
DN65	72.1	76.1	91	28
DN80	84.3	88.9	106	28
DN100	109.7	114.3	130	28
DN125	134.5	139.7	155	28
DN150	163.1	168.3	183	28
DN200	213.9	219.1	233.5	28

DIN 快装接头
DIN Ferrule

SIZE	ØA	ØB	ØA	ØB	ØC	L
DN6	6	8	—	—	25	12.7
DN8	8	10	—	—	25	12.7
DN10	10	13	9	12	34	18
DN15	16	19	15	18	34	18
DN20	20	23	19	22	34	18
DN25	26	29	25	28	50.5	21.5
DN32	32	35	31	34	50.5	21.5
DN40	38	41	37	40	50.5	21.5
DN50	50	53	49	52	64	21.5
DN65	66	70	66	70	91	28
DN80	81	85	81	85	106	28
DN101.6	—	—	97.6	101.6	119	28
DN100	100	104	100	104	119	28
DN125	125	129	125	129	155	28
DN150	150	154	150	154	183	28
DN200	200	204	200	204	233.5	28

13IS I-LINE卡箍
13IS I-LINE CLAMP

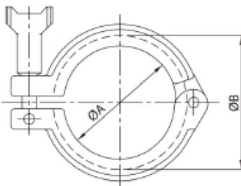

SIZE	ØA	ØB
1.0"~1.5"	44.4	53.4
2.0"	60.14	72.2
2.5"	78.62	88.1
3.0"	93.06	102.4
4.0"	118.6	127.8
6.0"	178.3	195.3

卫生级卡箍接头
Sanitary Ferrule

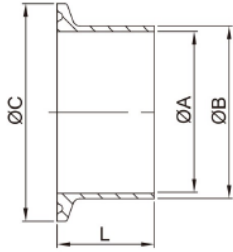

ISO(REP) 快装接头
ISO(REP) Ferrule

SIZE	ØA	ØB	ØC1	L
DN8	10.3	13.5	34	28.6
DN10	14	17.2	34	28.6
DN15	18.1	21.3	34	28.6
DN20	23.7	26.9	50.5	28.6
DN25	30.5	33.7	50.5	28.6
DN32	39.2	42.4	50.5	28.6
DN40	45.1	48.3	64	28.6
DN50	56.3	60.3	77.5	28.6
DN65	72.1	76.1	91	28.6
DN80	84.3	88.9	106	28.6
DN100	109.7	114.3	130	28.6
DN125	133.7	139.7	155	28.6
DN150	162.3	168.3	183	28.6
DN200	211.1	219.1	233.5	28.6
DN250	266.3	273.1	233.5	28.6

ISO-2852 快装接头
ISO-2852 Ferrule

SIZE	ØA	ØB	ØC	L
25	22.6	25.6	50.5	21.5
33.7	31.3	34.3	50.5	21.5
38	35.6	38.6	50.5	21.5
40	37.6	40.6	64	21.5
51	48.6	51.6	64	21.5
63.5	60.3	64.1	77.5	21.5
70	66.8	70.6	91	21.5
76.1	72.9	76.7	91	21.5
88.9	84.9	89.8	106	21.5
101.6	97.6	102.5	119	21.5
114.3	110.3	115.6	130	28
139.7	135.7	141.2	155	28
168.3	163.1	170	183	28
219.1	213.9	221.2	233.5	28

IDF/JIS 快装接头
IDF/JIS Ferrule

SIZE	ØA	ØB	ØC	L
1.05	23	25.4	50.5	21.5
1.255	29.4	31.8	50.5	17
1.55	35.7	38.1	50.5	21.5
2.05	47.8	50.8	64	21.5
2.55	59.5	63.5	77.5	21.5
3.05	72.3	76.3	91	21.5
3.55	85.1	89.1	106	21.5
4.05	97.6	101.6	119	28
4.55	108.3	114.3	130	28
5.55	133.8	139.8	165	28
6.55	159.2	165.2	183	28

卫生级卡箍接头
Sanitary Ferrule

14MPHT 加长快装接头
14MPHT Heavy Tank Ferrule

SIZE	ØA	ØB	ØC	L	L
1/2"	9.4	12.7	25	44.45	101.6
3/4"	15.75	19.05	25	44.45	101.6
1.0"	22.1	25.4	50.5	114.3	—
1.5"	34.8	38.1	50.5	114.3	—
2.0"	47.5	50.8	64	114.3	—
2.5"	60.2	63.5	77.5	114.3	—
3.0"	72.9	76.2	91	114.3	—
4.0"	97.4	101.6	119	117.9	—
6.0"	146.86	152.4	166.87	152.4	—

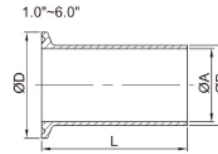
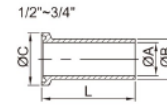

14MPW 加长快装接头
14MPW Heavy Tank Ferrule

SIZE	ØA	ØB	ØC	L
1/2"	8.15	12.75	25	54
3/4"	14.6	19.05	25	54
1.0"	22.1	29.5	50.5	41.3
1.5"	34.8	42.6	50.5	41.3
2.0"	47.5	55.7	64	44.5
2.5"	60.2	68.8	77.5	44.5
3.0"	72.9	81.9	91	46.1
4.0"	97.4	108.1	119	54
6.0"	146.25	157.3	166.87	63.5
8.0"	197.05	208.1	217.67	63.5

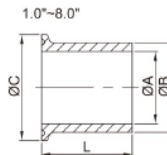
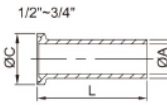

14RMP 3A-膨胀(扩展)接头
14RMP 3A-Roll-on ferrule

SIZE	ØA	ØB	ØC	L
1.0"	25.4	29.5	50.5	19.1
1.25"	31.75	36.3	50.5	21.5
1.5"	38.1	42.6	50.5	28.6
2.0"	50.8	55.7	64	33.3
2.5"	63.5	68.8	77.5	34.9
3.0"	76.2	81.9	91	36.5
4.0"	101.6	108.1	119	38.1

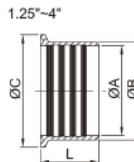
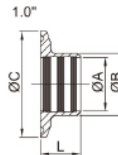

卫生级卡箍接头
Sanitary Ferrule

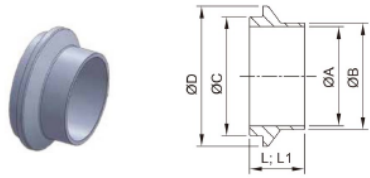

14WI I-Line Ferrule公头
14WI I-Line Ferrule Male

SIZE	ØA	ØB	ØC	ØD	L	L1
1.0"	22.1	25.4	31.5	50.67	19.84	44.65
1.5"	34.8	38.1	44.2	50.67	23.8	51.75
2.0"	47.5	50.8	56.9	67.05	26.19	58.88
2.5"	60.2	63.5	69.6	84	29.36	63.47
3.0"	72.9	76.2	83.82	98.3	30.94	68.17
4.0"	97.4	101.6	109.14	123.7	34.11	76.17
6.0"	146.86	152.4	173.5	190.4	28.58	73.1
8.0"	197.66	203.2	224.3	241.2	28.58	73.1

15WI I-line Ferrule 内螺纹
15WI I-Line Ferrule Female

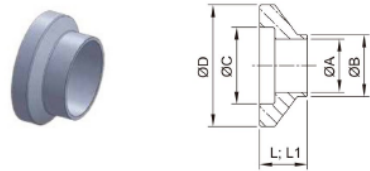

SIZE	ØA	ØB	ØC	ØD	L	L1
1.0"	22.1	25.4	31.88	50.67	19.84	44.5
1.5"	34.8	38.1	44.58	50.67	23.8	51.6
2.0"	47.5	50.8	57.28	67.05	26.19	58.7
2.5"	60.2	63.5	69.98	84	29.36	63.5
3.0"	72.9	76.2	84.2	98.3	30.94	68.3
4.0"	97.4	101.6	109.6	123.7	34.11	76.2
6.0"	146.86	152.4	175.7	190.4	28.58	76.2
8.0"	197.66	203.2	226.5	241.2	28.58	76.2

16AI-14I 外螺纹端盖
16AI-14I Male I-Line End Cap

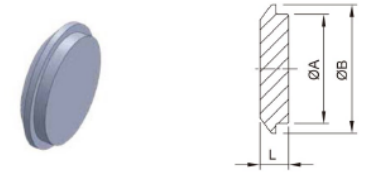

SIZE	ØA	ØB	L
1.0"	31.5	50.67	12.37
1.5"	44.2	50.67	12.37
2.0"	56.9	67.05	14.11
2.5"	69.6	84	18.72
3.0"	83.82	98.3	19.32
4.0"	109.14	123.7	19.32
6.0"	173.5	190.4	18.88
8.0"	224.3	241.2	18.88

16AI-15I 内螺纹端盖
16AI-15I Female I-Line End Cap



SIZE	ØA	ØB	L
1.0"	31.88	50.67	12.75
1.5"	44.58	50.67	12.75
2.0"	57.28	67.05	17.66
2.5"	69.98	84	18.77
3.0"	84.2	98.3	19.37
4.0"	109.6	123.7	19.37
6.0"	175.7	190.4	22
8.0"	226.5	241.2	22

卫生级卡箍接头
Sanitary Ferrule

13PG

1/2"-3/4"

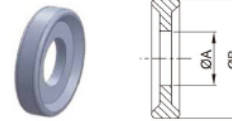

1"~8"
DN10~DN200

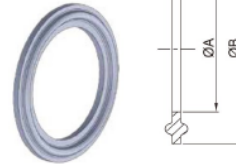

13PG (EPDM, SILICONE, VITON, PTFE)

Imperial	ØA	ØB
1/2"	9.9	21.8
3/4"	16.3	21.8
A37	19	33
1"	22.7	50
1.25"	29.5	50.5
1.5"	35.9	50
2"	48.6	63.5
2.5"	61.3	76.2
3"	74	88.9
3.5"	86	105
4"	98.6	118
4.5"	110.5	129
5"	134.7	153
6"	147.8	165
8"	198.6	216

ISO(PTFE)	ØA	ØB	DIN(EPDM)	ØA	ØB
DN8	11.1	33.2	DN10	9.8	33.2
DN12	14.8	33.2	DN15	15.8	33.2
DN15	18.9	33.2	DN20	19.8	33.2
DN20	24.5	49.7	DN28	25.8	49.7
DN25	31.3	49.7	DN34	31.8	49.7
DN32	40	49.7	DN40	37.8	49.7
DN40	45.9	63.2	DN52	49.8	63.2
DN50	57.1	76.7	DN70	66.8	90.2
DN65	72.9	90.2	DN85	81.8	105.2
DN80	85.7	105.2	DN101.6	98.4	118.2
DN100	109.9	129.2	DN104	100.8	118.2
DN125	134.5	154.2	DN125	125.8	154.2
DN150	163.1	182.2	DN150	150.8	182.2
DN200	211.9	232.7	DN200	200.8	232.7

13PG(EP+PT)

1/2"

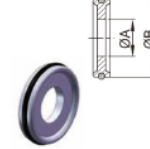

3/4"

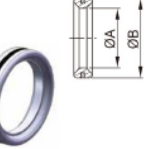

1.0"~4.0"



英制13PG(EP+PT)
Imperial 13PG(EP+PT)

SIZE	ØA	ØB
1/2"	10	21.5
3/4"	16.3	21.8
1"	22.5	50.2
1.5"	34.9	50.2
2"	47.6	63.5
2.5"	60.5	77.7
3"	73.2	90.5
4"	97.7	118.4

13FG

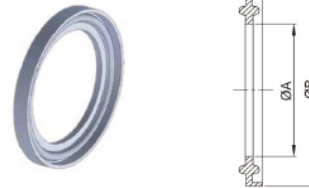

法兰盘式13FG
FLANGE TYPE 13FG

SIZE	ØA	ØB
1"	22.8	52.7
1.5"	35.8	52.7
2"	48.8	66.2
2.5"	60.5	79.7
3"	73.1	93.2
4"	97.8	121.2
6"	148	169.1
10"	249	270.7
12"	300	321.5

卫生级卡箍接头
Sanitary Ferrule

1/2"~3/4"
DIN6~DIN8

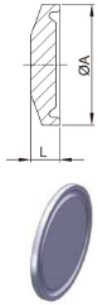

A37~12"
DIN10~DIN200
ISO(REP)

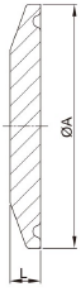

英制 Imperial 16AMP DIN 16AMP ISO(REP) 16AMP

SIZE	ØA	L	SIZE	ØA	L	SIZE	ØA	L
1/2"	25	6	DN6	25	4.75	DN8	34	6.3
3/4"	25	6	DN8	25	4.75	DN12	34	6.3
A37	34	6.3	DN10	34	6.35	DN15	34	6.3
1.0"	50.5	6.3	DN15	34	6.35	DN20	50.5	6.3
1.5"	50.5	6.3	DN20	34	6.35	DN25	50.5	6.3
2.0"	64	6.3	DN25	50.5	6.35	DN32	50.5	6.3
2.5"	77.5	6.3	DN32	50.5	6.35	DN40	64	6.3
3.0"	91	6.3	DN40	50.5	6.35	DN50	77.5	6.3
3.5"	106	6.3	DN50	64	6.35	DN65	91	6.3
4.0"	119	7.9	DN65	91	6.35	DN80	106	6.3
6.0"	166.87	11.1	DN80	106	6.35	DN100	130	7.9
8.0"	217.67	11.1	DN100	119	8	DN125	155	7.9
10"	268.47	11.1	DN125	155	8	DN150	183	11.1
12"	319.27	11.1	DN150	183	11.1	DN200	233.5	11.1
			DN200	233.5	11.1			

14WHR 软管接头
14WHR HOSE ADAPTER

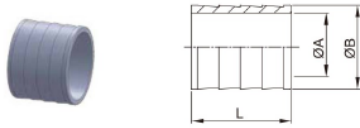

SIZE	ØA	ØB	ØC	L
1/2"	9.5	13.7	25.2	25.3
3/4"	15.8	21.4	25.2	25.3
1.0"	20.6	25.4	50.5	30.3
1.5"	33.2	38.1	50.5	30.3
2.0"	46	50.8	64	46
2.5"	58.7	63.5	77.5	46.8
3.0"	72	76.2	91	65.9
4.0"	97.6	101.6	119	72.8

14MPHR 软管接头
14MPHR HOSE ADAPTER

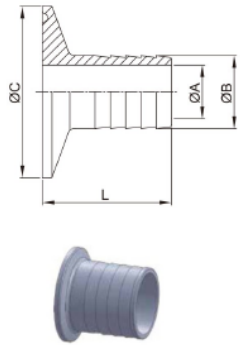

SIZE	ØA	ØB	ØC	L	SIZE	ØA	ØB	ØC	L
1/2*1/4"	3.175	7.3	25.2	38	1.0*1.0"	20.6	25.4	50.5	43
1/2*3/8"	6.35	10.4	25.2	38	1.5*3/8"	6.35	10.4	50.5	38
1/2*1/2"	9.5	13.7	25.2	38	1.5*1/2"	9.5	13.7	50.5	38
1/2*5/8"	12.7	16.8	25.2	38	1.5*5/8"	12.7	16.8	50.5	38
3/4*1/4"	3.175	7.3	25.2	38	1.5*3/4"	15.8	21.4	50.5	38
3/4*3/8"	6.35	10.4	25.2	38	1.5*1.0"	20.6	25.4	50.5	43
3/4*1/2"	9.5	13.7	25.2	38	1.5*1.25"	26.8	31.75	50.5	43
3/4*5/8"	12.7	16.8	25.2	38	1.5*1.5"	33.2	38.1	50.5	43
3/4*3/4"	15.8	21.4	25.2	38	2.0*1.25"	26.8	31.75	64	43
1.0*1/4"	3.175	7.3	50.5	38	2.0*1.5"	33.2	38.1	64	43
1.0*3/8"	6.35	10.4	50.5	38	2.0*2.0"	46	50.8	64	58.7
1.0*1/2"	9.5	13.7	50.5	38	2.5*2.5"	58.7	63.5	77.5	59.5
1.0*5/8"	12.7	16.8	50.5	38	3.0*3.0"	72	76.2	91	78.6
1.0*3/4"	15.8	21.4	50.5	38	4.0*4.0"	97.6	101.6	119	85.5

卫生级卡箍接头
Sanitary Ferrule

19W外螺纹
19W thread male

SIZE	ØA	ØB	NPT	L
1/2"	9.4	12.7	1/2"	41.3
3/4"	15.75	19.05	3/4"	41.3
1.0"	22.1	25.4	1.0"	44.5
1.5"	34.8	38.1	1.5"	44.5
2.0"	47.5	50.8	2.0"	46
2.5"	60.2	63.5	2.5"	58.7
3.0"	72.9	76.2	3.0"	63.5
4.0"	97.4	101.6	4.0"	65.1
6.0"	146.9	152.4	6.0"	76.2

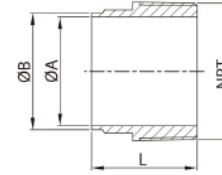
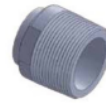

21MP

SIZE	ØA	ØC	NPT	L	SIZE	ØA	ØC	NPT	L
1/2**1/2"	9.5	25	1/2"	45	2.0**3.0"	73	64	3.0"	70
3/4**1/4"	7.95	25	1/4"	45	2.0**4.0"	97.6	64	4.0"	75
3/4**1/2"	15.8	25	1/2"	45	2.5**1.0"	22.2	77.5	1.0"	50
3/4**3/4"	15.8	25	3/4"	45	2.5**1.5"	34.9	77.5	1.5"	50
1.0**1.5**1/4"	3.18	50.5	1/4"	40	2.5**2.0"	47.6	77.5	2.0"	55
1.0**1.5**3/8"	6.35	50.5	3/8"	40	2.5**2.5"	60.3	77.5	2.5"	60
1.0**1.5**1/2"	9.5	50.5	1/2"	40	2.5**3.0"	73	77.5	3.0"	70
1.0**1.5**3/4"	15.8	50.5	3/4"	45	2.5**4.0"	97.6	77.5	4.0"	75
1**1.5**1.0"	22.2	50.5	1.0"	50	3.0**1.0"	22.2	91	1.0"	55
1.0**1.5**1.25"	28.6	50.5	1.25"	50	3.0**1.5"	34.9	91	1.5"	55
1.0**1.5**1.5"	34.9	50.5	1.5"	50	3.0**2.0"	47.6	91	2.0"	55
1.0**1.5**2.0"	47.6	50.5	2.0"	55	3.0**2.5"	60.3	91	2.5"	60
2.0**1/4"	3.18	64	1/4"	40	3.0**3.0"	73	91	3.0"	70
2.0**3/8"	6.35	64	3/8"	40	3.0**4.0"	97.6	91	4.0"	75
2.0**1/2"	9.5	64	1/2"	40	4.0**1.0"	22.2	119	1.0"	55
2.0**3/4"	15.8	64	3/4"	50	4.0**1.5"	34.9	119	1.5"	55
2.0**1.0"	22.2	64	1.0"	50	4.0**2.0"	47.6	119	2.0"	55
2.0**1.5"	34.9	64	1.5"	50	4.0**2.5"	60.3	119	2.5"	60
2.0**2.0"	47.6	64	2.0"	55	4.0**3.0"	73	119	3.0"	70
2.0**2.5"	60.3	64	2.5"	60	4.0**4.0"	97.6	119	4.0"	75

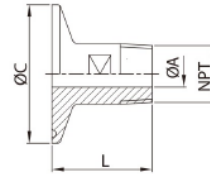

22W内螺纹
22W thread female

SIZE	ØA	ØB	NPT	L
1.0"	22.1	25.4	1.0"	34.9
1.5"	34.8	38.1	1.5"	33.4
2.0"	47.5	50.8	2.0"	44.5
2.5"	60.2	63.5	2.5"	46.1
3.0"	72.9	76.2	3.0"	57.2
4.0"	97.4	101.6	4.0"	60.3

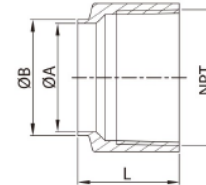
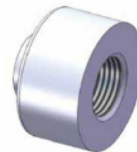

卫生级卡箍接头 Sanitary Ferrule

22MP

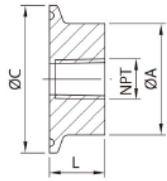

SIZE	ØA	ØC	L	NPT	SIZE	ØA	ØC	L	NPT
1.0"×1.5"×1/4"	38.1	50.5	19	1/4"	2.5"×1.0"	63.5	77.5	35	1.0"
1.0"×1.5"×3/8"	38.1	50.5	19	3/8"	2.5"×1.5"	63.5	77.5	35	1.5"
1.0"×1.5"×1/2"	38.1	50.5	19	1/2"	2.5"×2.0"	65	77.5	35	2.0"
1.0"×1.5"×3/4"	38.1	50.5	19	3/4"	3.0"×1.0"	76.2	91	35	1.0"
1.0"×1.5"×1.0"	40	50.5	19	1.0"	3.0"×1.5"	76.2	91	35	1.5"
2.0"×1/4"	50.8	64	19	1/4"	3.0"×2.0"	76.2	91	35	2.0"
2.0"×3/8"	50.8	64	19	3/8"	4.0"×1.0"	101.6	119	35	1.0"
2.0"×1/2"	50.8	64	19	1/2"	4.0"×1.5"	101.6	119	35	1.5"
2.0"×3/4"	50.8	64	19	3/4"	4.0"×2.0"	101.6	119	35	2.0"
2.0"×1.0"	50.8	64	19	1.0"	4.0"×2.5"	101.6	119	35	2.5"
2.0"×1.5"	53	64	19	1.5"	4.0"×3.0"	101.6	119	35	3.0"

22MP

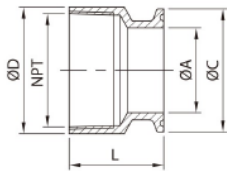

SIZE	1.0" ØA	1.5" ØA	ØC	ØD	NPT	L
1/2"×1/4"	9.5		25	30	1/4"	33
1/2"×1/2"	9.5		25	30	1/2"	33
3/4"×1/2"	15.75		25	30	1/2"	38.1
3/4"×3/4"	15.8		25	31	3/4"	33
1.0"×1.5"×1.25"	22.2	34.9	50.5	52	1.25"	39
1.0"×1.5"×1.5"	22.2	34.9	50.5	54	1.5"	39
1.0"×1.5"×2.0"	22.2	34.9	50.5	65	2.0"	40
2.0"×2.0"	47.6		64	65	2.0"	40
2.5"×2.5"	60.3		77.5	80	2.5"	50
3.0"×2.5"	73		91	95	2.5"	50
3.0"×3.0"	73		91	95	3.0"	52
4.0"×4.0"	97.6		119	120	4.0"	54

23BMP

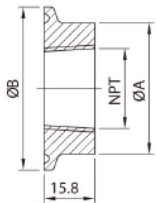

SIZE	ØA	ØB	NPT	SIZE	ØA	ØB	NPT
1.0"×1/8"	25.4	50.5	1/8"	2.5"×1/2"	63.5	77.5	1/2"
1.0"×1/4"	25.4	50.5	1/4"	2.5"×3/4"	63.5	77.5	3/4"
1.0"×3/8"	25.4	50.5	3/8"	2.5"×1.0"	63.5	77.5	1.0"
1.0"×1/2"	25.4	50.5	1/2"	2.5"×1.5"	63.5	77.5	1.5"
1.5"×1/8"	38.1	50.5	1/8"	2.5"×2.0"	63.5	77.5	2.0"
1.5"×1/4"	38.1	50.5	1/4"	3.0"×1/2"	76.2	91	1/2"
1.5"×3/8"	38.1	50.5	3/8"	3.0"×3/4"	76.2	91	3/4"
1.5"×1/2"	38.1	50.5	1/2"	3.0"×1.0"	76.2	91	1.0"
1.5"×3/4"	38.1	50.5	3/4"	3.0"×1.5"	76.2	91	1.5"
1.5"×1.0"	38.1	50.5	1.0"	3.0"×2.0"	76.2	91	2.0"
2.0"×1/2"	50.8	64	1/2"	4.0"×3/4"	101.6	119	3/4"
2.0"×3/4"	50.8	64	3/4"	4.0"×1.0"	101.6	119	1.0"
2.0"×1.0"	50.8	64	1.0"	4.0"×1.5"	101.6	119	1.5"
2.0"×1.5"	50.8	64	1.5"	4.0"×2.0"	101.6	119	2.0"
				4.0"×2.5"	101.6	119	2.5"
				4.0"×3.0"	101.6	119	3.0"

管支架 HANGERS

TH-1



Type A

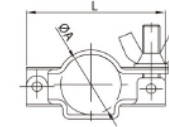

Type B

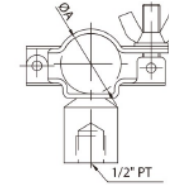

Type C

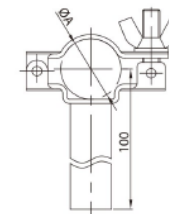

Imperial	ØA	L
1"	25.4	66
1.5"	38.1	76
2"	50.8	90
2.5"	63.5	105
3"	76.2	120
4"	101.6	146

DIN	ØA	L
DN15	18/19	69
DN20	22/23	66
DN25	28/29	64.5
DN32	34/35	78.5
DN40	40/41	80.5
DN50	52/53	94
DN65	70	123.5
DN80	85	130.5
DN100	104	150
DN125	129	175.5
DN150	154	206.5

TH-2



Type A

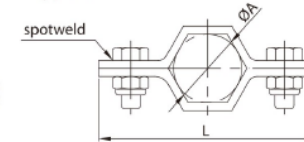

Type C

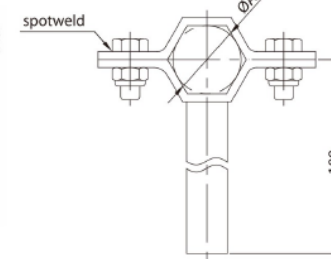

ISO	ØA	L
ISO-21.3	21.3	68
ISO-26.9	26.9	74
ISO-33.7	33.7	82
ISO-42.4	42.4	93
ISO-48.3	48.3	101
ISO-60.3	60.3	114
ISO-88.9	88.9	149
ISO-114.3	114.3	177
ISO-139.7	139.7	221.7
ISO-168.7	168.7	254.8

SMS	ØA	L
DN25	25	74
DN38	38	87
DN50	51	105
DN63	63.5	117
DN76	76.1	133
DN100	104	165
DN125	139.7	221.7
DN150	168.3	254.8

TH-3



Type A

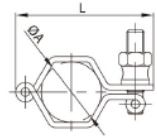

Type B

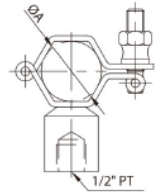

Type C

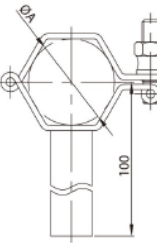

TH-3 (六角形 Hexagon)

DIN	ØA	L
DN25	28	64
DN32	34	64
DN40	40	78
DN50	52	90
DN65	70	111
DN80	85	129
DN100	101.6	150

SMS	ØA	L
DN25	25	61
DN38	38	76
DN50	51	90
DN63	63.5	106
DN76	76.1	124
DN100	104	154

TH-4 (RG type)

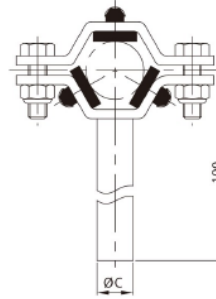
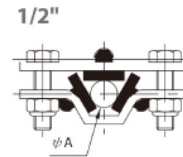

3/4"~6.0"

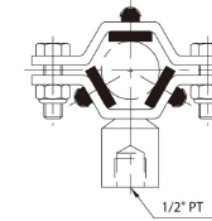
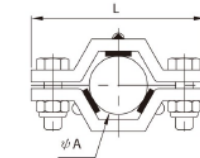

TH-4

SIZE	ØA	ØC	L
1/2"	12.7	12.7	79
3/4"	19.05	12.7	79
1.0"	25.4	15.9	79
1.5"	38.1	19	95
2.0"	50.8	19	117.9
2.5"	63.5	19	120
3.0"	76.2	19	135.1
4.0"	101.6/104	19	168.4
6.0"	152.4	19	225

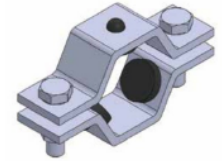

TH-4 (PP type)

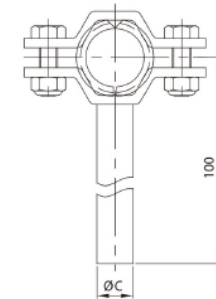
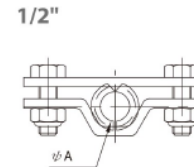

3/4"~6.0"

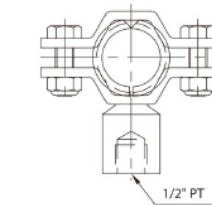
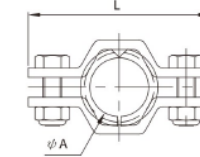

TH-4

SIZE	ØA	ØC	L
1/2"	12.7	12.7	79
3/4"	19.05	12.7	79
1.0"	25.4	15.9	79
1.5"	38.1	19	95
2.0"	50.8	19	117.9
2.5"	63.5	19	120
3.0"	76.2	19	135.1
4.0"	101.6/104	19	168.4
6.0"	152.4	19	225

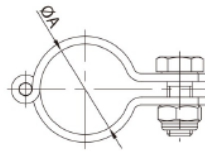
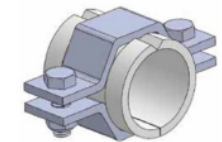

TH-3 (六角形 Hex) 铰链式管夹 (圆形)
Hinged pipe clamp (Round) agon

DIN	ØA	L
DN20	23	57
DN25	29	63
DN32	35	67
DN40	41	73
DN50	53	91
DN65	70	108
DN80	85	123
DN100	104	142

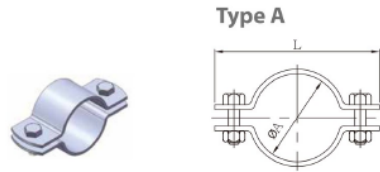

Type A

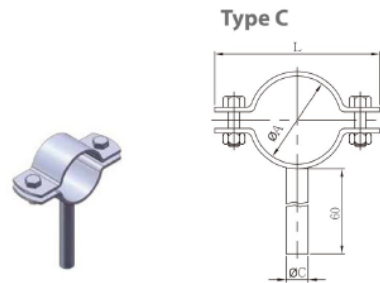

Type C

TH-5

3A	ØA	ØC	L
1/2"	12.7	6	46.5
3/4"	19.05	8	50
1.0"	25.4	8	62.5
1.25"	31.75	10	70.5
1.5"	38.1	10	81.5
2.0"	50.5	12	92
2.5"	63.5	12	123.5
3.0"	76.2	15	141
4.0"	101.6	15	177.5
5.0"	127	18	201
6.0"	152.4	18	231.5
8.0"	203.2	—	279.5

DIN	ØA	L	ØC
DN10	12/13	46.5	6
DN15	18/19	50	8
DN20	22/23	55	8
DN25	28/29	73.5	8
DN32	34/35	70.5	10
DN40	40/41	80.4	10
DN50	52/53	96.5	12
DN65	70	120	12
DN80	85	137	15
DN100	104	182	15
DN125	129	202	18
DN150	154	231	18

TH-6

SIZE	ØA	H	L
1/2"	12.7	90	83
3/4"	19.05	90	83
1"	25.4	90	83
1.5"	38.1	90	97.7
2"	50.8	90	111.7
2.5"	63.5	90	124
3"	76.2	90	140.5
4"	101.6	90	162
6"	152.4	145	217

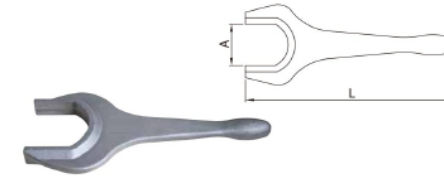
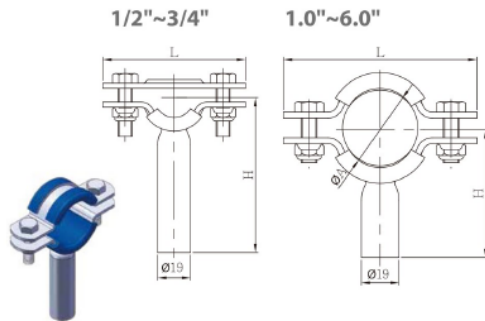

六角扳手 HEXAGONAL SPANNER

SIZE	3A	A	RJT	L
1.0"	47	51.8	240	
1.5"	62.1	66	288	
2.0"	77.2	80.4	300	
2.5"	92.5	93.2	326	
3.0"	107.9	106.3	440	
4.0"	131.5	139.1	448	

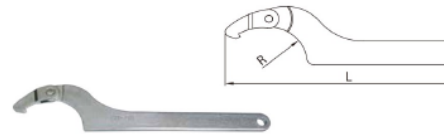

丁字扳手 DIN SPANNER

SIZE	R	L
DN10~DN20	22	175
DN25~DN40	31	247
DN50~DN100	49	290
DN125~DN150	82.5	515

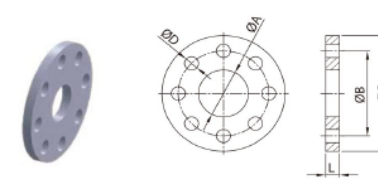

备用法兰盘 BACK-UP FLANGE

SIZE	ØA	ØB	ØC	ØD	L
1"	27	79.4	108	4-15.9	9.5
1.5"	39.7	98.4	127	4-15.9	9.5
2"	52.4	120.7	152.4	4-19.05	11.1
2.5"	65.1	139.7	177.8	4-19.05	11.1
3"	77.8	152.4	190.5	4-19.05	12.7
4"	103.2	190.5	228.6	8-19.05	12.7
6"	154	241.3	279.4	8-22.2	14.3

翻边接头 14VB STUB END

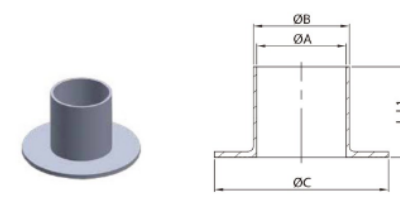

SIZE	ØA	ØB	ØC	L	L1
1/2"	9.4	12.7	38.1	6.5	28.6
3/4"	15.75	19.05	38.1	6.5	34.9
1"	22.1	25.4	50.8	6.5	41.3
1.5"	34.8	38.1	73	6.5	44.5
2"	47.5	50.8	92.1	6.5	38.1
2.5"	60.2	63.5	104.8	6.5	50.8
3"	72.9	76.2	127	7.4	57.2
4"	97.4	101.6	157.2	7.4	66.7
6"	146.86	152.4	215.9	8.8	76.2
8"	197.66	203.2	269.9	8.8	76.2
10"	247.6	254	323.85	25.4	88.9
12"	298	304	381	25.4	76.2

封头 16W CAP

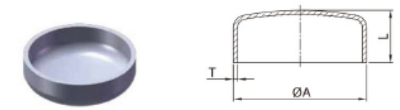

SIZE	ØA	T	L
1/2"	12.7	1.65	6.4
3/4"	19.05	1.65	7.9
1"	25.4	1.65	19.1
1.5"	38.1	1.65	14.2
2"	50.8	1.65	19.1
2.5"	63.5	1.65	25.4
3"	76.2	1.65	31.8
4"	101.6	2.1	38.1
6"	152.4	2.77	57.2

卫生级由任(DIN 11851)
Sanitation Unions(DIN 11851)

DIN-13R

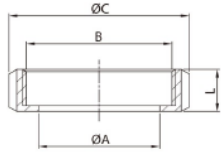

DIN-13RBN

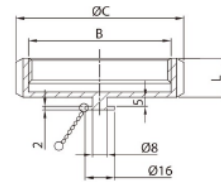

DIN-13 圆螺母
DIN-13 ROUND NUT

SIZE	ØA	B	ØC	L	SLOTS
10	19	RD 28*1/8	38	18	4
15	25	RD 34*1/8	44	18	4
20	31	RD 44*1/6	54	20	4
25	36	RD 52*1/6	63	21	4
32	42	RD 58*1/6	70	21	4
40	49	RD 65*1/6	78	21	4
50	62	RD 78*1/6	92	22	4
60	70	RD 85*1/6	99	22	4
65	80	RD 95*1/6	112	25	6
80	94	RD110*1/4	127	29	6
90	104	RD120*1/4	138	30	6
100	115	RD130*1/4	148	31	6
125	138	RD160*1/4	178	35	6
150	164	RD190*1/4	210	40	6

卫生级由任(DIN 11851)
Sanitation Unions(DIN 11851)

DIN-13 圆螺母
DIN-13 ROUND NUT

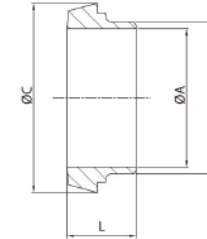

SIZE	ØA	ØB	ØC	L
10	10	15	22.5	17
15	16	21	28.5	17
20	20	25	36.5	18
25	26	31	44	22
32	32	37	50	25
40	38	43	56	26
50	50	55	68.5	28
60	57	63	76	30
65	66	72	86	32
80	81	87	100	37
100	99	104	121	44
125	100	106	121	44
125	125	132	150	34
150	150	157	176	37

DIN-14DA/DB 平接头
DIN-14DA/DB WELDING LINER

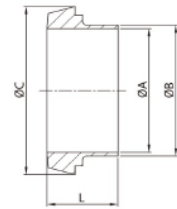

SIZE	ØA	DA ØB	DB ØA	DB ØB	ØC	L
10	10	13	9	12	22.5	17
15	16	19	15	18	28.5	17
20	20	23	19	22	36.5	18
25	26	29	25	28	44	22
32	32	35	31	34	50	25
40	38	41	37	40	56	26
50	50	53	49	52	68.5	28
60	57	61	57	61	76	30
65	66	70	66	70	86	32
80	81	85	81	85	100	37
100	100	104	100	104	121	44
125	125	129	125	129	150	34
150	150	154	150	154	176	37

DIN-15 平接头
DIN-15 WELDING MALE

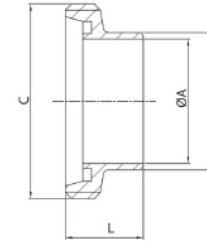

SIZE	ØA	ØB	C	L
10	10	15	RD 28*1/8	21
15	16	21	RD 34*1/8	21
20	20	25	RD 44*1/6	24
25	26	31	RD 52*1/6	29
32	32	37	RD 58*1/6	32
40	38	43	RD 65*1/6	33
50	50	55	RD 78*1/6	35
60	57	63	RD 85*1/6	36
65	66	72	RD 95*1/6	40
80	81	87	RD 110*1/4	45
100	99	104	RD 130*1/4	54
100	100	106	RD 130*1/4	54
125	125	132	RD 160*1/4	46
150	150	157	RD 190*1/4	50

DIN-15DA/DB 螺纹接头
DIN-15DA/DB WELDING MALE

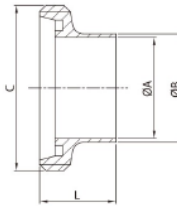

SIZE	ØA	DA ØB	DB ØA	DB ØB	C	L
10	10	13	9	12	RD 28*1/8	21
15	16	19	15	18	RD 34*1/8	21
20	20	23	19	22	RD 44*1/6	24
25	26	29	25	28	RD 52*1/6	29
32	32	35	31	34	RD 58*1/6	32
40	38	41	37	40	RD 65*1/6	33
50	50	53	49	52	RD 78*1/6	35
60	57	61	57	61	RD 85*1/6	36
65	66	70	66	70	RD 95*1/6	40
80	81	85	81	85	RD 110*1/4	45
90	89	93	89	93	RD 120*1/4	54
100	100	104	100	104	RD 130*1/4	54
125	125	129	125	129	RD 160*1/4	46
150	150	154	150	154	RD 190*1/4	50

DIN密封圈(三元乙丙、硅胶、氟橡胶、聚四氟乙烯)
DIN SEAL RING(EPDM, SILICONE, VITONG(FKM), PTFE)

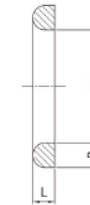

SIZE	ØA	B	L
10	12	4	4.5
15	18	4	4.5
20	23	5	4.5
25	30	5	5
32	36	5	5
40	42	5	5
50	54	5	5
65	71	5	5
80	85	5	5
100	104	5	5
125	130	6	7
150	155	6	7

卫生级由任(DIN 11851)
Sanitation Unions(DIN 11851)

卫生级由任(DIN 11851)
Sanitation Unions(DIN 11851)

DIN-14T 平接头
DIN-14T WELDING LINER

SIZE	ØA	ØB	ØC	L
10	10	18	22.5	17
15	16	24	28.5	17
20	20	30	36.5	18
25	26	35	44	22
32	32	41	50	25
40	38	48	56	26
50	50	61	68.5	28
65	66	79	86	32
80	81	93	100	37
100	99	112	121	44
125	100	114	121	44
125	125	137	150	34
150	150	163	176	37

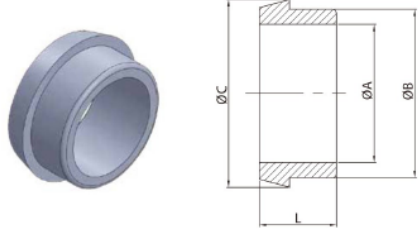

DIN-15T 螺纹接头
DIN-15T WELDING MALE

SIZE	ØA	ØB	C	L
10	10	18	RD 28*1/8	21
15	16	24	RD 34*1/8	21
20	20	30	RD 44*1/6	24
25	26	35	RD 52*1/6	29
32	32	41	RD 58*1/6	32
40	38	48	RD 65*1/6	33
50	50	61	RD 78*1/6	35
65	66	79	RD 95*1/6	40
80	81	93	RD 110*1/4	45
100	99	112	RD 130*1/4	54
100	100	114	RD 130*1/4	54
125	125	137	RD 160*1/4	46
150	150	163	RD 190*1/4	50

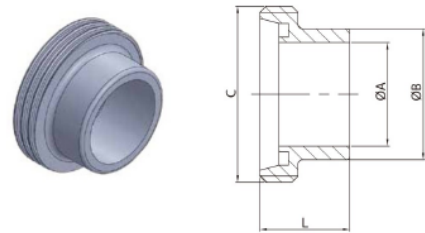

DIN-14B 盲盖
DIN-14B END CAP

SIZE	ØA	ØB	L
10	18	22.5	9
15	24	28.5	9
20	30	36.5	11
25	35	44	13
32	41	50	13
40	48	56	13
50	61	68.5	14
65	79	86	16
80	93	100	16
90	103	111	19
100	114	121	20
125	137	150	22
150	163	176	24

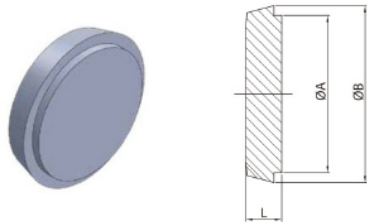

DIN-14R 膨胀(扩展型)接头 DIN-14R Expanding liner

SIZE	ØA	ØB	ØC	ØD	L
10	10	12.2	18	22.5	17
15	16	18.2	24	28.5	17
20	20	22.2	30	36.5	18
25	26	28.2	35	44	22
32	32	34.2	41	50	25
40	38	40.3	48	56	26
50	50	52.3	61	68.5	28
65	66	70.4	79	86	32
80	81	85.4	93	100	37
100	100	105	114	121	44
125	125	129	137	150	34
150	150	154	163	176	37

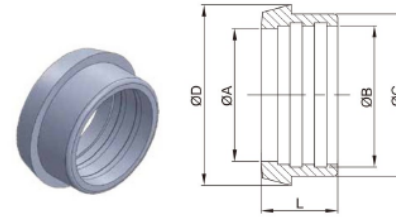

DIN-15R 膨胀(扩展型)螺纹接头 DIN-15R Expand Male

SIZE	ØA	ØB	ØC	D	L
10	10	12.2	18	RD 28*1/8	21
15	16	18.2	24	RD 34*1/8	21
20	20	22.2	30	RD 44*1/6	24
25	26	28.2	35	RD 52*1/6	29
32	32	34.2	41	RD 58*1/6	32
40	38	40.3	48	RD 65*1/6	33
50	50	52.3	61	RD 78*1/6	35
65	66	70.4	79	RD 95*1/6	40
80	81	85.4	93	RD 110*1/4	45
100	100	105	114	RD 130*1/4	54
125	125	129	137	RD 160*1/4	46
150	150	154	163	RD 190*1/4	50

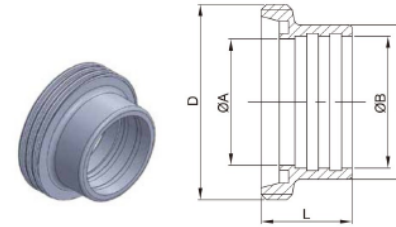

DIN-14I 平接头 DIN-14I imperial welding liner

SIZE	ØA	ØB	ØC	ØD	L
1/2"	9.4	12.7	10	22.5	17
3/4"	15.75	19.05	20	36.5	18
1"	22.1	25.4	26	44	22
1.25"	28.45	31.75	32	50	25
1.5"	34.8	38.1	38	56	26
2"	47.5	50.8	50	68.5	28
2.5"	60.2	63.5	66	86	32
3"	72.9	76.2	81	100	37
4"	97.6	101.6	100	121	44

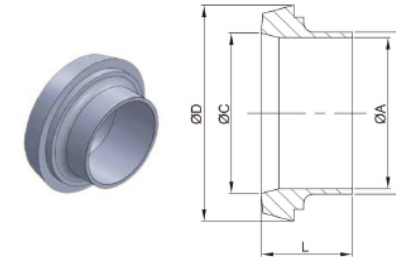

DIN-15I 螺纹接头 DIN-15I imperial welding male

SIZE	ØA	ØB	ØC	D	L
1/2"	9.4	12.7	10	RD 28*1/8	21
3/4"	15.75	19.05	20	RD 44*1/6	24
1"	22.1	25.4	26	RD 52*1/6	29
1.25"	28.45	31.75	32	RD 58*1/6	32
1.5"	34.8	38.1	38	RD 65*1/6	33
2"	47.5	50.8	50	RD 78*1/6	35
2.5"	60.2	63.5	66	RD 95*1/6	40
3"	72.9	76.2	81	RD 110*1/4	45
4"	97.6	101.6	100	RD 130*1/4	54

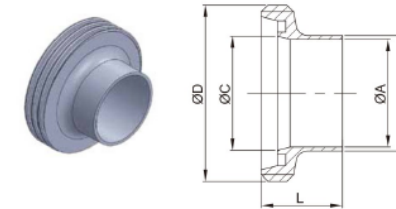

卫生级由任(DIN 11851)
Sanitation Unions(DIN 11851)

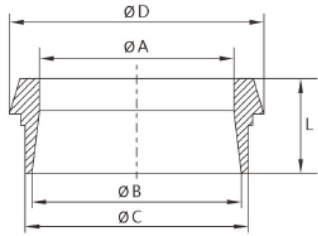

平接头
SHORT WELDING LINER

SIZE	ØA	ØB	ØC	ØD	L
17.2	10	14	17.2	22.5	17
21.3	16	18.1	21.3	28.5	17
26.9	20	23.7	26.9	36.5	18
33.7	26	29.7	33.7	44	22
42.4	32	38.4	42.4	50	25
48.3	38	44.3	48.3	56	26
60.3	50	56.3	60.3	68.5	28
76.1	66	71.5	76.1	86	32
88.9	81	84.3	88.9	100	37
114.3	100	109.1	114.3	121	44
139.7	125	134.5	139.7	150	34
168.3	150	163.1	168.3	176	37

螺纹接头
SHORT WELDING MALE

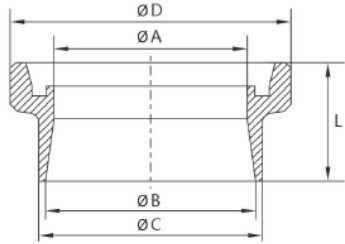

SIZE	ØA	ØB	ØC	ØD	L
10	10	14	17.2	Rd28x1/8"	21
15	16	18.1	21.3	Rd34x1/8"	21
20	20	23.7	26.9	Rd44x1/6"	24
25	26	29.7	33.7	Rd52x1/6"	29
30	32	38.4	42.4	Rd58x1/6"	32
40	38	44.3	48.3	Rd65x1/6"	33
50	50	56.3	60.3	Rd78x1/6"	35
65	56	71.5	76.1	Rd95x1/6"	40
80	81	84.3	88.9	Rd110x1/4"	45
100	100	109.1	114.3	Rd130x1/4"	54
125	125	134.5	139.7	Rd160x1/4"	46
150	150	163.1	168.3	Rd190x1/4"	50

软管接头
HOSE ADAPTER

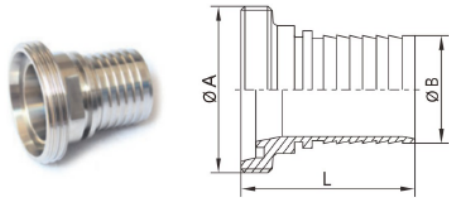

SIZE	ØA	ØB	L
20	Rd44x1/6"	19	64
25	Rd52x1/6"	25	73
38	Rd65x1/6"	38	74
50	Rd78x1/6"	50	80.5
65	Rd95x1/6"	63	106.5
80	Rd110x1/4"	76	118.5
100	Rd130x1/4"	102	128.5

软管接头
HOSE ADAPTER

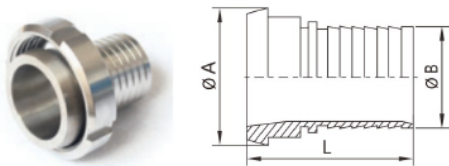

SIZE	ØA	ØB	L
20	36.5	19	61
25	44	25	66
38	56	38	69
50	68	50	82.5
65	86	63	100.5
80	100	76	108.5
100	121	102	124.5

卫生级由任(DIN 11853-1)
Sanitation Unions(DIN 11853-1)

DIN-13R圆螺母
DIN-13R ROUND NUT

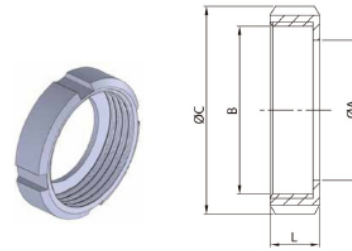

SIZE	ØA	B	ØC	L	SLOTS
10	19	RD 28*1/8	38	18	4
15	25	RD 34*1/8	44	18	4
20	31	RD 44*1/6	54	20	4
25	36	RD 52*1/6	63	21	4
32	42	RD 58*1/6	70	21	4
40	49	RD 65*1/6	78	21	4
50	62	RD 78*1/6	92	22	4
60	70	RD 85*1/6	99	22	4
65	80	RD 95*1/6	112	25	6
80	94	RD110*1/4	127	29	6
90	104	RD120*1/4	138	30	6
100	115	RD130*1/4	148	31	6
125	138	RD160*1/4	178	35	6
150	164	RD190*1/4	210	40	6

平接头
LINER PARTS

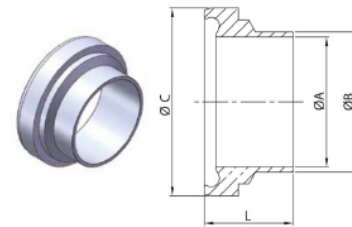

DIN	ØA	ØB	ISO	ØA	ØB	INCH	ØA	ØB	ØC	L
DN10	10	13	DN8	10.3	13.5	1/2"	9.4	12.7	21.9	17
DN15	16	19	DN10	14	17.2	3/4"	15.75	19.5	27.9	17
DN20	20	23	DN15	18.1	21.3	—	—	—	35.9	18
DN25	26	29	DN20	23.7	26.9	1"	22.1	25.4	42.9	22
DN32	32	35	DN25	29.7	33.7	—	—	—	48.9	25
DN40	38	41	DN32	38.4	42.4	1.5"	34.8	38.1	54.9	26
DN50	50	53	DN40	44.3	48.3	2"	47.5	50.8	66.9	30
DN65	66	70	DN50	56.3	60.3	2.5"	60.2	63.5	84.9	34
DN80	81	85	DN65	72.1	76.1	3"	72.9	76.2	98.9	38
DN100	100	104	DN80	84.3	88.9	4"	97.38	101.6	118.9	46

螺纹接头
MALE PARTS

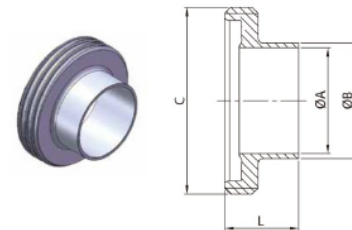

DIN	ØA	ØB	ISO	ØA	ØB	INCH	ØA	ØB	C	L
DN10	10	13	DN8	10.3	13.5	1/2"	9.4	12.7	RD28*1/8	19
DN15	16	19	DN10	14	17.2	3/4"	15.75	19.5	RD34*1/8	19
DN20	20	23	DN15	18.1	21.3	—	—	—	RD44*1/6	21
DN25	26	29	DN20	23.7	26.9	1"	22.1	25.4	RD52*1/6	26
DN32	32	35	DN25	29.7	33.7	—	—	—	RD58*1/6	30
DN40	38	41	DN32	38.4	42.4	1.5"	34.8	38.1	RD65*1/6	31
DN50	50	53	DN40	44.3	48.3	2"	47.5	50.8	RD78*1/6	31
DN65	66	70	DN50	56.3	60.3	2.5"	60.2	63.5	RD95*1/6	36
DN80	81	85	DN65	72.1	76.1	3"	72.9	76.2	RD110*1/4	42
DN100	100	104	DN80	84.3	88.9	4"	97.38	101.6	RD130*1/4	50

卫生级由任(DIN 11853-1 & 11864-1)
Sanitation Unions(DIN 11853-1 & 11864-1)

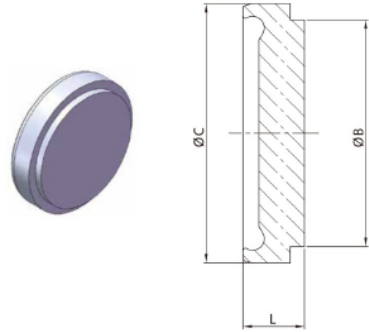

DIN/ISO/盲接头
DIN/ISO/IMPERIAL-LINER BLANK CAP

SIZE	ØB	ØC	L
DN10	1/2"	18	21.9
DN15	3/4"	24	27.9
DN20	30	35.9	10
DN25	1"	35	42.9
DN32	41	48.9	13
DN40	1.5"	48	54.9
DN50	2"	61	66.9
DN65	2.5"	79	84.9
DN80	3"	93	98.9
DN100	4"	114	118.9

卫生级由任(DIN 11864-1)
Sanitation Unions(DIN 11864-1)

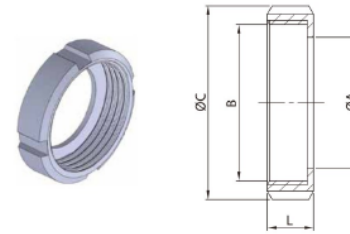

DIN-13R 圆螺母
DIN-13R ROUND NUT

SIZE	ØA	B	ØC	L	SLOTS
10	19	RD 28*1/8	38	18	4
15	25	RD 34*1/8	44	18	4
20	31	RD 44*1/6	54	20	4
25	36	RD 52*1/6	63	21	4
32	42	RD 58*1/6	70	21	4
40	49	RD 65*1/6	78	21	4
50	62	RD 78*1/6	92	22	4
60	70	RD 85*1/6	99	22	4
65	80	RD 95*1/6	112	25	6
80	94	RD 110*1/4	127	29	6
90	104	RD 120*1/4	138	30	6
100	115	RD 130*1/4	148	31	6
125	138	RD 160*1/4	178	35	6
150	164	RD 190*1/4	210	40	6

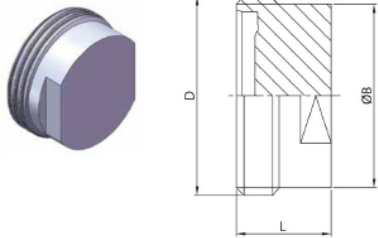

DIN/ISO/盲螺纹接头
DIN/ISO/IMPERIAL-MALE BLANK CAP

DIN/ISO	L	Imperial	L	ØB	D
DN10	19	1/2"	24	23	RD28*1/8
DN15	19	3/4"	24	28	RD34*1/8
DN20	21	—	—	34	RD44*1/6
DN25	26	1"	24	44	RD52*1/6
DN32	30	—	—	53	RD58*1/6
DN40	31	1.5"	24	60	RD65*1/6
DN50	31	2"	24	72	RD78*1/6
DN65	36	2.5"	28	87	RD95*1/6
DN80	42	3"	28	100	RD110*1/4
DN100	50	4"	30	120	RD130*1/4

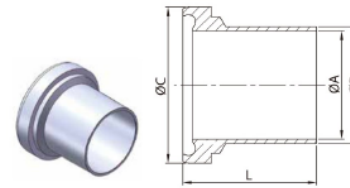

平接头
LINER PARTS

DIN	ØA	ØB	L	ISO	ØA	ØB	L	INCH	ØA	ØB	L	ØC
DN10	10	13	39	DN8	10.3	13.5	39	1/2"	9.4	12.7	39	21.9
DN15	16	19	39	DN10	14	17.2	39	3/4"	15.75	19.5	39	27.9
DN20	20	23	38	DN15	18.1	21.3	40	—	—	—	—	35.9
DN25	26	29	40	DN20	23.7	26.9	41	1"	22.1	25.4	40	42.9
DN32	32	35	47	DN25	29.7	33.7	47	—	—	—	—	48.9
DN40	38	41	47	DN32	38.4	42.4	47	1.5"	34.8	38.1	46.5	54.9
DN50	50	53	48	DN40	44.3	48.3	48	2"	47.5	50.8	47.5	66.9
DN65	66	70	61	DN50	56.3	60.3	62	2.5"	60.2	63.5	63	84.9
DN80	81	85	61	DN65	72.1	76.1	61	3"	72.9	76.2	61	98.9
DN100	100	104	66	DN80	84.3	88.9	68	4"	97.38	101.6	65	118.9

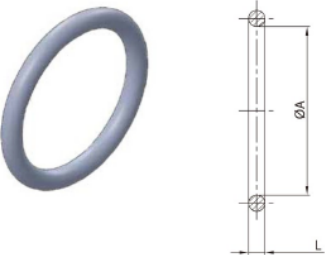

密封圈
SEAL

DIN	ØA	ISO	ØA	INCH	ØA	L
DN10	12	DN8	12	1/2"	12	3.5
DN15	18	DN10	16	3/4"	18	3.5
DN20	22	DN15	20	—	—	3.5
DN25	28	DN20	26	1"	24	3.5
DN32	34	DN25	32	—	—	5
DN40	40	DN32	40.5	1.5"	37	5
DN50	52	DN40	46.5	2"	50	5
DN65	68	DN50	58.5	2.5"	62	5
DN80	83	DN65	73.5	3"	75	5
DN100	102	DN80	86.5	4"	100	5

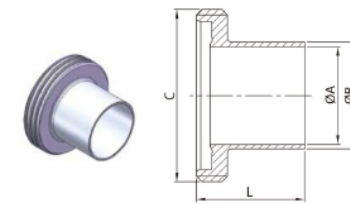

螺纹接头
MALE PARTS

DIN	ØA	ØB	L	ISO	ØA	ØB	L	INCH	ØA	ØB	L	C
DN10	10	13	41	DN8	10.3	13.5	41	1/2"	9.4	12.7	41	RD28*1/8
DN15	16	19	41	DN10	14	17.2	41	3/4"	15.75	19.5	41	RD34*1/8
DN20	20	23	43	DN15	18.1	21.3	43	—	—	—	—	RD44*1/6
DN25	26	29	43	DN20	23.7	26.9	43	1"	22.1	25.4	43	RD52*1/6
DN32	32	35	48	DN25	29.7	33.7	48	—	—	—	—	RD58*1/6
DN40	38	41	48	DN32	38.4	42.4	48	1.5"	34.8	38.1	48.5	RD65*1/6
DN50	50	53	48	DN40	44.3	48.3	49	2"	47.5	50.8	48.5	RD78*1/6
DN65	66	70	60	DN50	56.3	60.3	60	2.5"	60.2	63.5	60	RD95*1/6
DN80	81	85	64	DN65	72.1	76.1	64	3"	72.9	76.2	64	RD110*1/4
DN100	100	104	64	DN80	84.3	88.9	64	4"	97.38	101.6	64	RD130*1/4

卫生级由任(DIN 11864-2)
Sanitation Unions(DIN 11864-2)

卫生级由任(SMS)
Sanitation Unions(SMS)

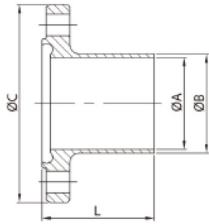

DIN 槽形法兰(NF)
DIN Nutflansch (NF)

SIZE	ØA	ØB	ØC	L
DN10	10	13	54	41.5
DN15	16	19	59	41.5
DN20	20	23	64	41.5
DN25	26	29	70	41.5
DN32	32	35	76	46.5
DN40	38	41	82	46.5
DN50	50	53	94	46.5
DN65	66	70	113	55.5
DN80	81	85	133	59.5
DN100	100	104	159	59.5
DN125	125	129	183	61.5
DN150	150	154	213	61.5

IMPERIAL 槽形法兰(NF)
IMPERIAL Nutflansch (NF)

SIZE	ØA	ØB	ØC	L
1/2"	9.4	12.7	54	41.5
3/4"	15.75	19.05	59	41.5
1"	22.1	25.4	66	41.5
1.5"	34.8	38.1	79	46.5
2"	47.5	50.8	92	46.5
2.5"	60.2	63.5	107	55.5
3"	72.9	76.2	125	57.5
4"	97.38	101.6	157	59.5



ISO 槽形法兰(NF)
ISO Nutflansch (NF)

SIZE	ØA	ØB	ØC	L
13.5	10.3	13.5	54	41.5
17.2	14	17.2	59	41.5
21.3	18.1	21.3	62	41.5
26.9	23.7	26.9	69	41.5
33.7	29.7	33.7	74	46.5
42.4	38.4	42.4	82	46.5
48.3	44.3	48.3	88	46.5
60.3	56.3	60.3	103	55.5
76.1	72.1	76.1	125	57.5
88.9	84.3	88.9	137	59.5
114.3	109.7	114.3	168	59.5

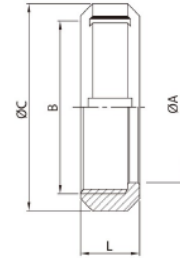

SMS-13R 螺母 6槽
SMS-13R NUT 6 SLOTS

SIZE	ØA	B	ØC	L
25	32.3	RD 40*1/6	51	19
32	40.3	RD 48*1/6	60	22
38	48.5	RD 60*1/6	74	23
50	61	RD 70*1/6	84	24
63	74	RD 85*1/6	100	28
76	87	RD 98*1/6	114	30
101.6	113	RD125*1/4	138	31
104	113	RD125*1/4	138	31
102.5	117	RD132*1/6	150	31

SMS-13RBN 盲螺母(盲盖)
SMS-13RBN ROUND BLANK NUT

SIZE	B	ØC	L
25	RD 40*1/6	51	19
32	RD 48*1/6	60	22
38	RD 60*1/6	74	23
50	RD 70*1/6	84	24
63	RD 85*1/6	100	28
76	RD 98*1/6	114	30
104	RD125*1/4	138	31
102.5	RD132*1/6	150	31

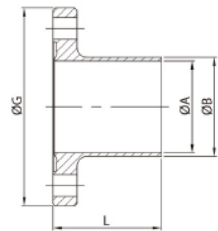
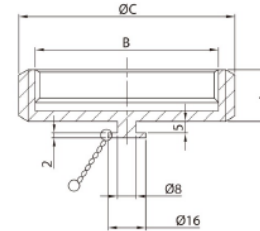

DIN 标准法兰(BF)
DIN Bundflansch (BF)

SIZE	ØA	ØB	ØC	L
DN10	10	13	54	40
DN15	16	19	59	40
DN20	20	23	64	40
DN25	26	29	70	40
DN32	32	35	76	45
DN40	38	41	82	45
DN50	50	53	94	45
DN65	66	70	113	54
DN80	81	85	133	58
DN100	100	104	159	58
DN125	125	129	183	60
DN150	150	154	213	60

IMPERIAL 标准法兰(BF)
IMPERIAL Bundflansch (BF)

SIZE	ØA	ØB	ØC	L
1/2"	9.4	12.7	54	40
3/4"	15.75	19.05	59	40
1"	22.1	25.4	66	40
1.5"	34.8	38.1	79	45
2"	47.5	50.8	92	45
2.5"	60.2	63.5	107	54
3"	72.9	76.2	125	56
4"	97.38	101.6	157	58

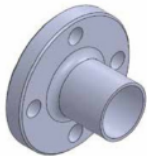

ISO 标准法兰(BF)
ISO Bundflansch (BF)

SIZE	ØA	ØB	ØC	L
13.5	10.3	13.5	54	40
17.2	14	17.2	59	40
21.3	18.1	21.3	62	40
26.9	23.7	26.9	69	40
33.7	29.7	33.7	74	45
42.4	38.4	42.4	82	45
48.3	44.3	48.3	88	45
60.3	56.3	60.3	103	54
76.1	72.1	76.1	125	56
88.9	84.3	88.9	137	58
114.3	109.7	114.3	168	58

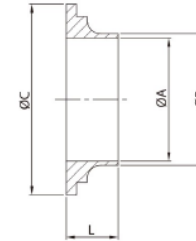

SMS-14 平接头
SMS-14 LONG WELDING LINER

SIZE	ØA	ØB	ØC	L
25	22.4	25.4	35.5	15.5
38	35.1	38.1	55	16
50	47.8	50.8	65	17
63	60.5	63.5	80	17
76	72.9	76.1	93	19
101.6	97.6	101.6	118	19
104	100	104	118	19
102.5	98.5	102.5	127	19

SMS-15 螺纹接头
SMS-15 LONG WELDING MALE

SIZE	ØA	ØB	ØC	L
25	22.4	25.4	RD 40*1/6	19
38	35.1	38.1	RD 60*1/6	23
50	47.5	50.8	RD 70*1/6	23
63	60.5	63.5	RD 85*1/6	27
76	72.9	76.1	RD 98*1/6	27
101.6	97.6	101.6	RD125*1/4	30
104	100	104	RD125*1/4	30
102.5	98.5	102.5	RD132*1/6	35

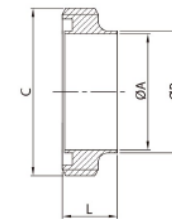

卫生级由任(SMS)
Sanitation Unions(SMS)

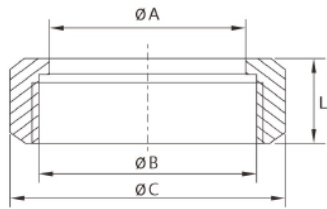

SMS 六角螺母
SMS Hex.nut

SIZE	ØA	ØB Max Min	ØC	L
1.0"	32	39.9 39.43	50	20
1.5"	48	59.9 59.43	72	22
2.0"	60.5	69.9 69.43	82	22
2.5"	74	84.9 84.3	97	25
3.0"	87	97.9 97.43	111	26
4.0"	112	124.9 124.43	138	30

卫生级由任(SMS)
Sanitation Unions(SMS)

SMS-14 AHR 软管接头
SMS-14AHR HOSE ADAPTER

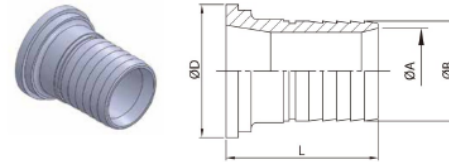

SIZE	ØA	ØB	ØD	L
25	22.2	25	35.5	60.5
38	34	38	55	72
50	47	50.5	65	82
63	59	63.2	80	95
76	71.5	75.5	93	97
104	95	100.8	118	109

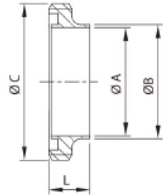

SMS-15S 螺纹接头
SMS-15S SHORT WELDING MALE

SIZE	ØA	ØB	C	L
25	22.4	25.4	RD 40*1/6	17
38	35.1	38.1	RD 60*1/6	20
50	47.5	50.8	RD 70*1/6	20
63	60.5	63.5	RD 85*1/6	24
76	72.9	76.1	RD 98*1/6	25
101.6	97.6	101.6	RD125*1/4	27
104	100	104	RD125*1/4	27
102.5	98.5	102.5	RD132*1/6	30

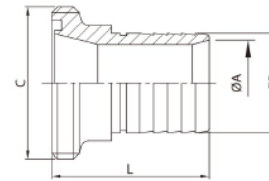

SMS-15 AHR 软管接头
SMS-15AHR HOSE ADAPTER

SIZE	ØA	ØB	C	L
25	22.2	25	RD 40*1/6	64
38	34	38	RD 60*1/6	79
50	47	50.5	RD 70*1/6	89
63	59	63.2	RD 85*1/6	102
76	71.5	75.5	RD 98*1/6	105
104	95	100.8	RD125*1/4	120

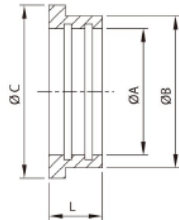

SMS-14R 膨胀平接头
SMS-14R EXPANDING LINER

SIZE	ØA	ØB	ØC	L
25	25	32	35.5	17
32	32	40	43.5	17
38	38	47.9	55	20
40	40	48	55	20
50	51	60.4	65	20
63	63.5	73.5	80	25
76	76.1	86.5	93	30
101.6	101.6	112.5	118	27
104	105	112.5	118	27

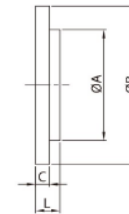

SMS-14B 盲接头
SMS-14B BLANK END CAP

SIZE	ØA	ØB	C	L
25	32	35.5	3.5	7.5
38	48	55	5	9
50	60	65	5	10
63	73.5	80	5	10
76	86	93	5	11
101.6/104	116	118	6	11
102.5	112	128	6	11

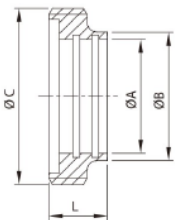

SMS-15R 螺纹接头
SMS-15R EXPANDING MALE

SIZE	ØA	ØB	C	L
25	25	32	RD 40*1/6	20
32	32	40	RD 48*1/6	20
38	38	47.9	RD 60*1/6	23
40	40	48	RD 60*1/6	23
50	51	60.4	RD 70*1/6	25
63	63.5	73.5	RD 85*1/6	30
76	76.1	86.5	RD 98*1/6	35
101.6	101.6	112.5	RD125*1/4	30
104	105	112.5	RD125*1/4	30

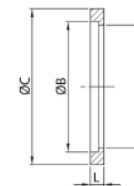

SMS-L型密封圈(三元乙丙、硅胶、氟橡胶、聚四氟乙烯)
SEAL RING L TYPE(EPDM, SILICONE, VITONG(FKM), PTFE)

SIZE	ØA	ØB	C	L
25	22.8	25.1	31.8	5.3
38	35.8	38.1	47.8	5.3
50	48.8	51.1	60.8	5.3
63	61	63.6	73.3	5.3
76	73.4	76.1	85.8	5.3
104/102.5	100.5	104	115.7	5.3

卫生级由任(RJT(BS))
Sanitation Unions(RJT(BS))

卫生级由任(RJT(BS))
Sanitation Unions(RJT(BS))

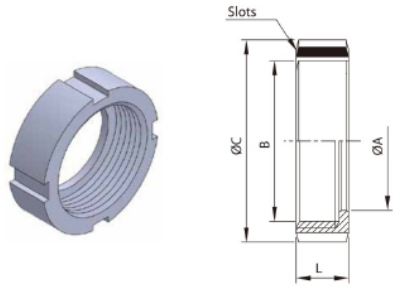

RJT-13R 圆螺母
RJT-13R Round nut

SIZE	ØA	B	ØC	L	Slots
1.0"	33.45	42.266x8TPI WHIT	58.5	22.2	4
1.5"	46	54.966x8TPI WHIT	74	22.2	4
2.0"	58.67	67.92x6TPI WHIT	85.5	22.2	4
2.5"	71.4	80.62x6TPI WHIT	98.5	22.2	4
3.0"	84.1	93.32x6TPI WHIT	111.6	22.2	4
4.0"	109.7	118.72x6TPI WHIT	138	22.2	4
6.0"	163	169.52x6TPI WHIT	197	23.5	4

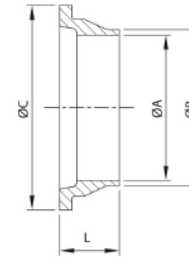

RJT-14 平接头
RJT-14 WELDING LINER

SIZE	ØA	ØB	ØC	L
1/2"	9.6	14	18	11
3/4"	16	20	23.1	11
1.0"	22.1	25.4	41.3	19
1.5"	34.8	38.1	54	19
2.0"	47.5	50.8	66.7	19
2.5"	60.2	63.5	79.4	19
3.0"	72.9	76.2	92.1	19
4.0"	97.6	101.6	117.5	19
6.0"	146.86	152.4	169.1	23

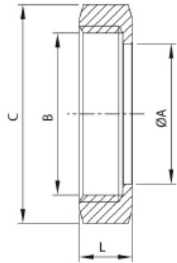
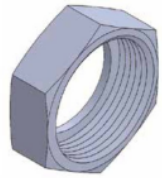

RJT-13H 六角螺母
RJT-13H Hex.nut

SIZE	ØA	B	C	L
1/2"	14.5	19.6x10TPI WHIT	28.5	16
3/4"	21	26.2x10TPI WHIT	33	16
1.0"	33.45	42.266x8TPI WHIT	50.8	22.2
1.5"	46	54.966x8TPI WHIT	65	22.2
2.0"	58.67	67.92x6TPI WHIT	79.4	22.2
2.5"	71.4	80.62x6TPI WHIT	92	22.2
3.0"	84.1	93.32x6TPI WHIT	104.8	22.2
4.0"	109.7	118.72x6TPI WHIT	130	22.2
6.0"	163	169.52x6TPI WHIT	184	24

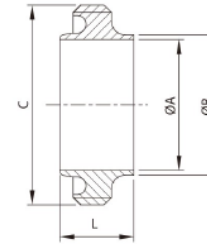

RJT-15 螺纹接头
RJT-15 WELDING MALE

SIZE	ØA	ØB	C	L
1/2"	9.6	13.7	21.2 *10TP WHIT	16.5
3/4"	16	20	27.6 *10TP WHIT	16.5
1.0"	22.1	25.4	45.72 *8TP WHIT	27
1.5"	34.8	38.1	58.42 *8TP WHIT	27
2.0"	47.5	50.8	72.72 *6TP WHIT	27
2.5"	60.2	63.5	85.42 *6TP WHIT	27
3.0"	72.9	76.2	98.12 *6TP WHIT	27
4.0"	97.6	101.6	123.52 *6TP WHIT	27
104	100	104	123.52 *6TP WHIT	27
6.0"	146.86	152.4	174.32 *6TP WHIT	24

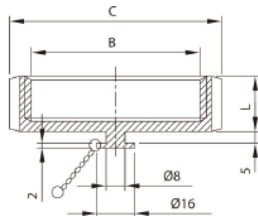
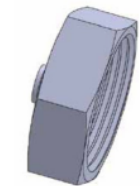

RJT-13HBN 盲螺母(盲盖)
RJT-13HBN Hex.blank nut

SIZE	B	C	L
1.0"	42.266x8TPI WHIT	50.8	23.5
1.5"	54.966x8TPI WHIT	65	23.5
2.0"	67.92x6TPI WHIT	79.4	23.5
2.5"	80.62x6TPI WHIT	92	23.5
3.0"	93.32x6TPI WHIT	104.8	23.5
4.0"	118.72x6TPI WHIT	130	23.5
6.0"	169.52x6TPI WHIT	184	23.5

O-Ring



U Type

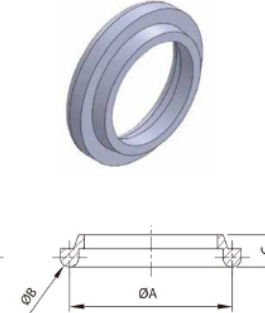

RJT-15 密封圈
RJT-15 SEAL RING

SIZE	ØA	ØB	C
1"	33.3	6.5	7
1.5"	46	6.5	7
2"	58.7	6.5	7
2.5"	71.4	6.5	7
3"	84.1	6.5	7
4"	109.5	6.5	7
6"	160.3	6.5	7

卫生级由任(RJT(BS))
Sanitation Unions(RJT(BS))

卫生级由任(IDF/JIS)
Sanitation Unions(IDF/JIS)

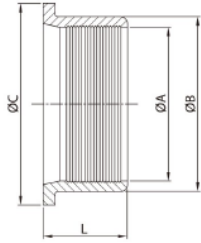
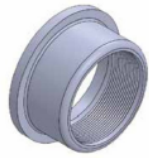

RJT-14R 膨胀平接头
RJT-14R EXPANDING LINER

SIZE	ØA	ØB	ØC	L
1"	25.4	32.5	41.3	20
1.5"	38.1	45.2	54	24
2"	50.8	57.9	66.7	28
2.5"	63.5	70.6	79.4	32
3"	76.2	83.3	92.1	32
4"	101.6	108.7	117.5	32

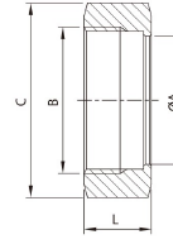
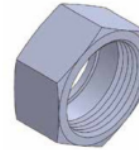

RJT-14R 六角螺母
RJT-14R HEXAGON NUT

SIZE	ØA	B	C	L
1.0"	30.5	34.49x8T ACME	46	30
1.5"	43.5	48.01x8T ACME	60	30
2.0"	57	61.52x8T ACME	75	30
2.5"	70.7	75.03x8T ACME	90	30
3.0"	83.3	88.55x8T ACME	105	30
4.0"	112	122.2x6T ACME	133	34.9

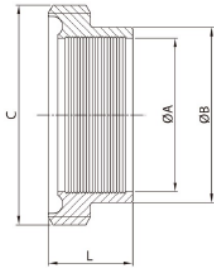

RJT-15R 膨胀螺纹接头
RJT-15R EXPANDING MALE

SIZE	ØA	ØB	C	L
1"	25.4	32.5	45.72 *8TP WHIT	20
1.5"	38.1	45.2	58.42 *8TP WHIT	24
2"	50.8	57.9	72.72 *6TP WHIT	28
2.5"	63.5	70.6	85.42 *6TP WHIT	32
3"	76.2	83.3	98.12 *6TP WHIT	32
4"	101.6	108.7	123.52*6TP WHIT	32

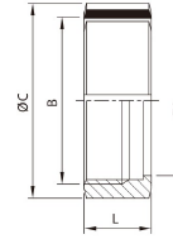
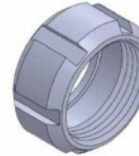

IDF-13R 圆螺母
IDF-13R Round nut

SIZE	ØA	B	ØC	L	Slots
1.0"	30.5	34.49x8T ACME	48	30	6
1.5"	43.5	48.01x8T ACME	64	30	6
2.0"	57	61.52x8T ACME	77	30	6
2.5"	70.7	75.03x8T ACME	91	30	6
3.0"	83.3	88.55x8T ACME	106	30	6
4.0"	110	115.56x8T ACME	135	34.9	6

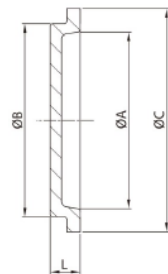

RJT-14B 盲盖
RJT-14B BLANK END CAP

SIZE	ØA	ØB	ØC	L
1"	27.8	32.5	41.3	9
1.5"	40.5	45.2	54	9
2"	53.2	57.9	66.7	9
2.5"	65.9	70.6	79.4	9
3"	78.6	83.3	92.1	9
4"/104	104	108.7	117.5	9

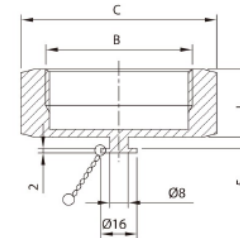

IDF-13HBN 盲螺母/盲盖
IDF-13HBN Hex.blank nut

SIZE	B	C	L
1.0"	34.49x8T ACME	46	30
1.5"	48.01x8T ACME	60	30
2.0"	61.52x8T ACME	75	30
2.5"	75.03x8T ACME	90	30
3.0"	88.55x8T ACME	105	30
4.0"	122.2x6T ACME	133	34.9

卫生级由任(IDF/JIS G3447)
Sanitation Unions(IDF/JIS G3447)

卫生级由任(IDF/JIS G3447)
Sanitation Unions(IDF/JIS G3447)

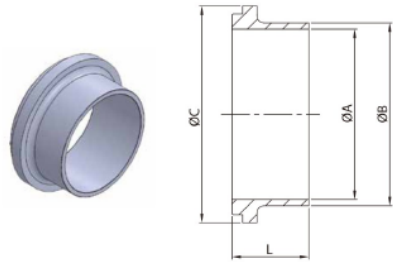

IDF-14 平接头
IDF-14 WELDING LINER

SIZE	IDF		JIS		ØC	L
	ØA	ØB	ØA	ØB		
1"	22.1	25.4	23	25.4	33.8	21.5
1.5"	34.8	38.1	35.7	38.1	47	21.5
2"	47.5	50.8	47.8	50.8	60.5	21.5
2.5"	60.2	63.5	59.5	63.5	74	21.5
3"	72.9	76.2	72.3	76.3	87.5	21.5
R 4"	97.6	101.6	—	—	114	30
H 4"	97.6	101.6	97.6	101.6	120.6	30

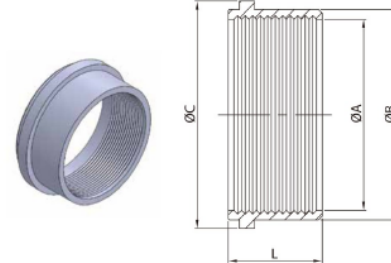

IDF-14R 平接头
IDF-14R RECESSLESS LINER

SIZE	ØA	ØB	ØC	L
1.5"	38.1	42.7	47	20
2"	50.8	56.2	60.5	25
2.5"	63.5	69.9	74	30
3"	76.2	82.6	87.5	30
R 4"	101.6	108.8	114	30
H 4"	101.6	111.1	120.6	30

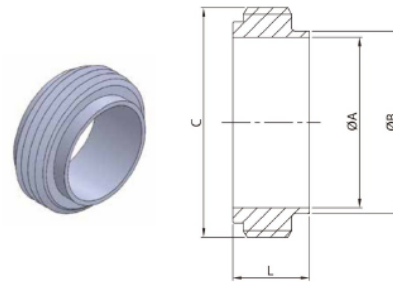

IDF-15 螺纹接头
IDF-15 WELDING MALE

SIZE	IDF		JIS		C	L
	ØA	ØB	ØA	ØB		
1"	22.1	25.4	23	25.4	36.97*8T ACME	21.5
1.5"	34.8	38.1	35.7	38.1	50.49*8T ACME	21.5
2"	47.5	50.8	47.8	50.8	64*8T ACME	21.5
2.5"	60.2	63.5	59.5	63.5	77.51*8T ACME	21.5
3"	72.9	76.2	72.3	76.3	91.03*8T ACME	21.5
R 4"	97.6	101.6	—	—	118.04*8T ACME	30
H 4"	97.6	101.6	97.6	101.6	125.69*6T ACME	30

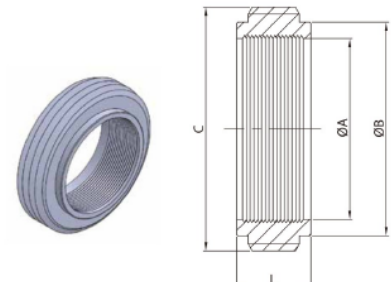

IDF-15R 螺纹接头
IDF-15R RECESSLESS MALE

SIZE	ØA	ØB	C	L
1.5"	38.1	42.7	50.49*8T ACME	19.5
2"	50.8	56.2	64*8T ACME	19.5
2.5"	63.5	69.9	77.51*8T ACME	25
3"	76.2	82.6	91.03*8T ACME	30
R 4"	101.6	108.8	118.04*8T ACME	35
H 4"	101.6	111.1	125.69*6T ACME	35

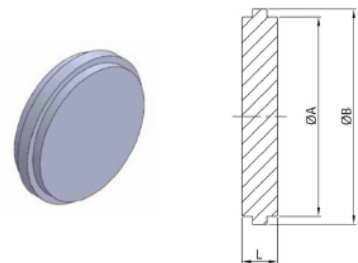

IDF-14B 盲盖
IDF-14B BLANK END CAP

SIZE	ØA	ØB	L
1"	29.2	33.8	10.5
1.5"	42.7	47	10.5
2"	56.2	60.5	10.5
2.5"	69.9	74	10.5
3"	82.6	87.5	10.5
R 4"	108.8	114.1	12.6
H 4"	111.1	120.6	12.6

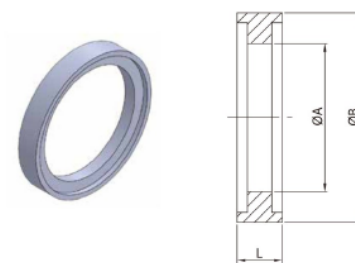

IDF密封圈
IDF SEAL RING

SIZE	ØA	ØB	L
1"	23	32.5	7
1.5"	36	46	7
2"	49	59.5	7
2.5"	60.7	73.2	7
3"	73.2	86.5	7
R 4"	98	113	7
H 4"	98	119.6	7

卫生级由任(MACON)
Sanitation Unions(MACON)

13R

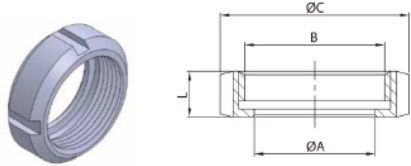

MACON螺母4槽M-13R
MACON NUT 4 SLOTS M-13R

SIZE	ØA	B	ØC	L
DN33	37	39*11TPI WHIT	50	25
DN43	47	M55*P3.0	70	25
DN53	57	M67*P3.0	80	25
DN63	67	M79*P3.5	95	25
DN73	77	M90*P3.5	106	25
DN83	90	M102*P4.0	118	25
DN103		M125*P4.0	139	26

13RBN

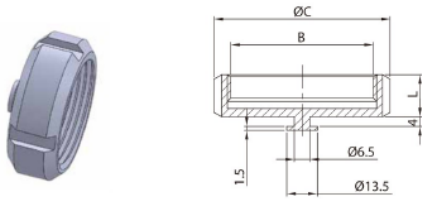

MACON平接头M-14
MACON LINER M-14

SIZE	ØA	ØB	ØC	ØD	ØE	L
DN33	33.3	36	28	31.5	38	22
DN38	38.2	46	35.9	44.5	50	29
DN40/43	43.3	46.3	40	44.5	50	22
DN51	51.2	56	48.5	54.5	62.5	29
DN50/53	53.3	56.3	50	54.5	62.5	22
DN60/63	63.3	66.3	60	64.5	73.5	22
DN70/73	73.3	76.3	70	74.5	85	22
DN76	72	76	70	74.5	85	22
DN80/83	83.3	86.3	80	84.5	96	22
DN103	104.2	108	100	104.5	119	22

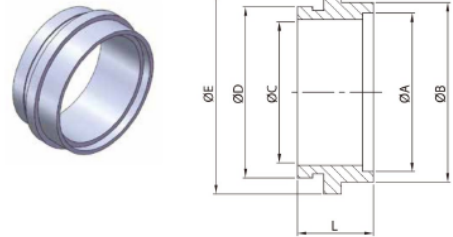

卫生级由任(MACON)
Sanitation Unions(MACON)

MACON 螺纹接头
MACON MALE M-15

SIZE	ØA	ØB	ØC	ØD	E	L
DN33	33.3	36.3	30	32	40.5*11TPI WHIT	22
DN38	38.2	46	35.9	45	M55*P3.0	30
DN43	43.3	46.3	40	45	M55*P3.0	22
DN51	51.2	56	48.5	55	M67*P3.0	30
DN53	53.3	56.3	50	55	M67*P3.0	22
DN60/63	63.3	66.3	60	66	M79*P3.5	22
DN70/73	73.3	76.3	70	76	M90*P3.5	22
DN76	72	76	70	76	M90*P3.5	22
DN80/83	83.3	86.3	80	86	M102*P4.0	22
DN103	104.2	108	100	106	M125*P4.0	22

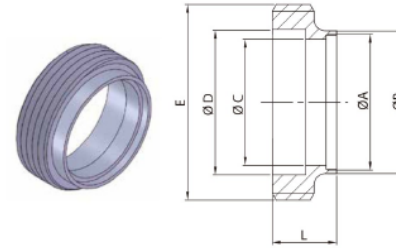

M-14AHR MACON 软管平接头
M-14AHR MACON LINER HOSE ADAPTER

SIZE	ØA	ØB	ØC	L
DN40/43	40	43	50.8	79
DN50/53	50	53	63	79
DN60/63	59	53.2	75	102
DN70/73	70	73	85	79
DN80/83	71.5	75.5	97	110

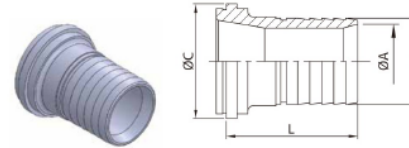

M-15AHR MACON 软管螺纹接头
M-15AHR MACON MALE HOSE ADAPTER

SIZE	ØA	ØB	C	L
DN40/43	40	43	M55*P3.0	79
DN50/53	50	53	M67*P3.0	79
DN60/63	59	53.2	M79*P3.5	104
DN70/73	70	73	M90*P3.5	79
DN80/83	71.5	75.5	M102*P4.0	112

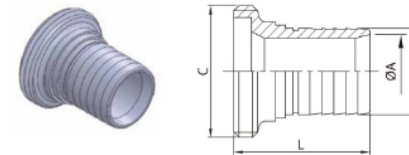

卫生级由任(3A)
Sanitation Unions(3A)

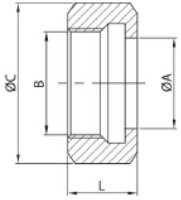
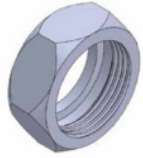

3A-13H 六角螺母
3A-13H HEXAGONAL NUT

SIZE	ØA	B	ØC	L
1"	30.3	38.02 ACME 8TPI	46	23
1.5"	43.4	51.54 ACME 8TPI	61.1	24.6
2"	56.5	65.05 ACME 8TPI	76.2	27
2.5"	69.6	78.56 ACME 8TPI	91.3	29.6
3"	82.7	92.08 ACME 8TPI	106.4	32.5
4"	108.9	120.14 ACME 6TPI	137.6	38.1

卫生级由任(3A)
Sanitation Unions(3A)

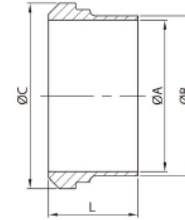

3A-14A 平接头
3A-14A LONG WELD LINER

SIZE	ØA	ØB	ØC	L
1"	22.1	25.4	33.3	34.9
1.5"	34.8	38.1	46.8	38.1
2"	47.5	50.8	60.3	38.1
2.5"	60.2	63.5	73.8	44.5
3"	72.9	76.2	87.3	44.5
4"	97.6	101.6	114.3	44.5

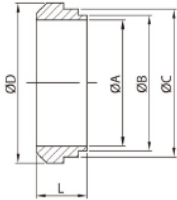

3A-14PRF 平接头
3A-14PRF SHORT BEVEL SEAT WELD LINER

SIZE	ØA	ØB	ØC	ØD	L
1"	22.1	25.4	29.5	33.3	18.3
1.5"	34.8	38.1	42.6	46.8	18.3
2"	47.5	50.8	55.7	60.3	19.1
2.5"	60.2	63.5	68.8	73.8	22.3
3"	72.9	76.2	81.9	87.3	23.1
4"	97.6	101.6	108.1	114.3	26.2

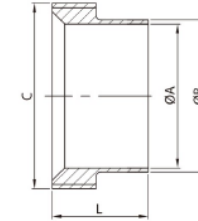

3A-15A 螺纹接头
3A-15A LONG WELD MALE

SIZE	ØA	ØB	C	L
1"	22.1	25.4	36.97 ACME 8TPI	34.9
1.5"	34.8	38.1	50.49 ACME 8TPI	38.1
2"	47.5	50.8	64 ACME 8TPI	38.1
2.5"	60.2	63.5	77.51 ACME 8TPI	44.5
3"	72.9	76.2	91.03 ACME 8TPI	44.5
4"	97.6	101.6	119.04 ACME 6TPI	44.5

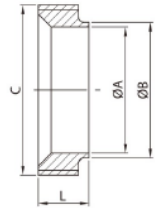

3A-15TRF 螺纹接头
3A-15TRF SHORT BEVEL SEAT WELD MALE

SIZE	ØA	ØB	C	L
1"	22.1	25.4	36.97 ACME 8TPI	18.3
1.5"	34.8	38.1	50.49 ACME 8TPI	18.3
2"	47.5	50.8	64 ACME 8TPI	19.1
2.5"	60.2	63.5	77.51 ACME 8TPI	22.2
3"	72.9	76.2	91.03 ACME 8TPI	23.1
4"	97.6	101.6	119.04 ACME 6TPI	26.2

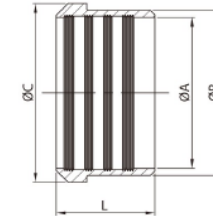
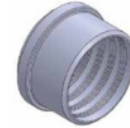

3A-14R 扩展平接头
3A-14R RECESSLESS LINER

SIZE	ØA	ØB	ØC	L
1"	25.4	29.5	33.3	19.1
1.5"	38.1	42.6	46.8	28.6
2"	50.8	55.7	60.3	33.3
2.5"	63.5	68.8	73.8	34.9
3"	76.2	81.9	87.3	36.5
4"	101.6	108.1	114.3	38.1

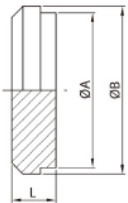

3A-16A 盲盖
3A-16A BLANK END CAP

SIZE	ØA	ØB	L
1"	29.5	33.3	11.9
1.5"	42.6	46.8	14.3
2"	55.7	60.3	15.9
2.5"	68.8	73.8	16.7
3"	81.9	87.3	18.3
4"	108.1	114.3	20.6

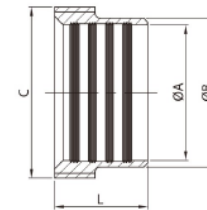

3A-15R 扩展螺纹接头
3A-15R RECESSLESS MALE

SIZE	ØA	ØB	C	L
1"	25.4	29.5	36.97 ACME 8TPI	20.6
1.5"	38.1	42.6	50.49 ACME 8TPI	28.6
2"	50.8	55.7	64 ACME 8TPI	34.9
2.5"	63.5	68.8	77.51 ACME 8TPI	38.1
3"	76.2	81.9	91.03 ACME 8TPI	41.3
4"	101.6	108.1	119.04 ACME 6TPI	41.3



Sanitary Manhole Cover

卫生级人孔盖系列



椭圆人孔盖(压力型) Elliptic Type Manhole Cover (With Pressure)

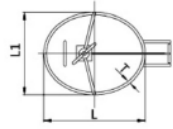

L	L1	T
430	330	8
535	435	10
635	525	12

椭圆人孔盖(压力型) Elliptic Type Manhole Cover (With Pressure)

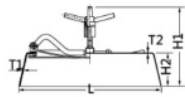

L大	L小	T1	T2	H1	H2
580	480	5	4	320	133

圆形人孔盖(压力型) Circular Type Manhole Cover (With Pressure)

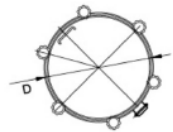

D	高度 (Height)	T
300	120	3
350	120	3
400	120	3
450	120	3
500	120	3
600	120	4

圆形人孔盖(非压力型) Circular Type Manhole Cover (With Pressure)

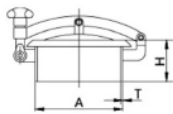

A	H	T
250	100	2
300	100	2
350	100	2
400	100	2
430	100	2.5
450	100	2.5
500	100	3
600	100	4

长方形人孔盖(压力型) Square Type Manhole Cover (With Pressure)

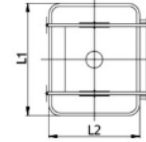

L1	L2	高度 (Height)	T
430	330	65	8
512	435	100	10

卫生级离心泵 Sanitary Centrifugal Pump

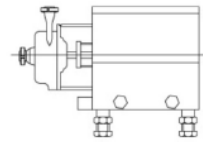

型号 Model	数量吨/h Quantity ton/h	扬程(米/水柱) Lift(meter/water column)	电动功率 Electric power	进出口 Entry/Exit
DJ1.5-14	1.5	14	0.5	40/25
DJ3-14	3	14	1.1	40/32
DJ5-24	5	24	1.5	50/40
DJ5-32	5	32	2.2	50/40
DJ10-24	10	24	2.2	50/40
DJ10-36	10	36	3	50/40
DJ15-24	15	24	3	50
DJ20-24	20	24	4	50
DJ20-36	20	36	5.5	50
DJ25-24	25	24	4	50/50
DJ30-24	30	24	5.5	65/50
DJ30-36	30	36	7.5	65/50
DJ30-60	30	60	11	65/50
DJ35-36	35	36	11	65/50
DJ40-36	40	36	11	80/65
DJ40-45	40	45	11	80/65
DJ50-36	50	36	11	80/65

卫生级自吸泵 Sanitary Self-Priming Pump

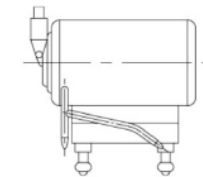

性能 Performance		主要参数 Parameter
流量Q	Flux	10-20m/h
总扬程H	Total lift	18-24m
吸程	Sucked lift	5-6m
叶轮轮幅直径	Impeller wheel axle diameter	φ189 mm
进出口管径	Entry/Exit diameter	φ51mm
功率	Power	4KW (380V.50HZ)
转速	Rotate speed	1420 r/min
外形尺寸(长×宽×高)	Size (Length X width X height)	600×350×420
机器重量	机器重量	55kg



Sanitary Butterfly Valves

卫生级蝶阀系列



卫生级气动 / 手动蝶阀 (RD) Sanitary Pneumatic/Manual Butterfly Valve (RD)

应用:

该类型阀门系列是一款卫生型自动或手动操作的蝶阀系列,广泛适用于不锈钢管道系统内调节介质流量的一类阀门。

Application:

The series of this valve is a kind of sanitary pneumatic or manual handle butterfly valve, which are widely used in stainless steel pipeline system to control and regulate medium flow.

工作原理:

该类型阀门既可以通过一个电动执行器或气动执行器进行远程遥控操作,也可以通过一个手柄进行人为操控。

电动执行器或气动执行器是将一个活塞的轴向运动转换为阀门轴的90°旋转,实现对管道流体的控制和开关任务。气动执行器装置有三种标准:常开(NO)型,常闭(NC)型,气/气(A/A)型。

鸭嘴式手动操作的多位手柄可通过15°位置的调节将阀门机械式锁定在其开启或关闭的12位子上,达到控制介质流量的目的:

拉杆式手动操作手柄通过4个多功能定位,将阀门机械式锁定在其开启或关闭的4个位子上,也达到控制介质流量的目的。

材料:

钢制部件: 不锈钢304、耐酸钢316L
密封圈: 硅橡胶 (VMQ)
氟橡胶 (FPM)
三元乙丙 (EPDM)

Material:

steel parts: stainless steel 304,
stainless steel 316L
Seal: silicone (VMQ)
fluoroelastomer (FPM),
EPDM



Work Principle:

This kind of valve can be handled both by manual or an electric actuator and also can be handled by a pneumatic actuator

Electric actuator or pneumatic actuator is to convert the axial movement of piston to be 90° rotation of valve shaft. So that the valve can be open or close to achieve the requirement of control and open/close for the pipeline system. They have three type of actuator: normally open (NO), normally closed (NC), air/air (A/A).

Multi-position handle regulates the valve by 15in its open or close 12 seat, and achieve control of medium flow purpose:

Pulling handle regulates the valve through four multi-function positioning, in its open or close four position, and also achieves control of medium flow purpose.



标准设计:

有各种标准的阀门系列可以向客户提供,即用于DIN标准系列,3A标准系列,ISO/IDF标准系列,BS/RJT标准系列,ASME/BPE等标准系列。

该阀门的组成部件一般包括:一个分为两半的阀体,阀门芯片,芯片轴的轴衬套以及轴密封圈,整个阀门是用螺栓及螺母组装在一起。三片式阀门同时还包括两个法兰以及两个法兰密封圈。

现有的蝶阀系列有:焊接式蝶阀、卡箍式蝶阀、外螺纹式蝶阀、焊接-外螺纹式蝶阀、由任-外螺纹式蝶阀、三片式蝶阀等各种蝶阀。

现有的执行器包括:1.不锈钢气动执行器,可提供φ85,φ108和φ133三种规格;2.铝制气动执行器,可提供ZT050D、ZT063D、ZT075D、ZT088D、ZT100D、ZT115D六种产品规格;3.电动执行器,可提供HL-05、HL-10、HL-20的产品规格。

执行器是用一个托架和螺丝固定在阀门上。

现有用于手动操作的手柄规格类型有:

- 1.拉杆手柄,可提供两种不同的产品规格;
- 2.多位不锈钢鸭嘴式手柄一种规格可配阀门规格: DN10~DN100/3A3/4"~4"/SMS 19~102/DS 1"~4"/ISO、IDF φ 19-φ 108
- 3.多位塑料鸭嘴式手柄一种规格可配阀门规格:(与不锈钢鸭嘴式手柄相同) 手动操作的手柄是用阀盖/轴系统和一颗螺丝固定在阀门上。

Standard Design:

Various standards of valves can be provided to clients: DIN,3A,SMS,ISO/IDF,BS/RJT,ASME/BPE etc.

The parts of valve usually include: two pieces body of valve, disc, gasket of valve disc, gasket, and the entire valve is assemble together with bolts and nuts.3 piece butterfly valve also include two flanges and two gaskets of flange.

This series of butterfly valve: welded, clamp, male, weld/male, union/male, three pieces ect.

The series of actuator: 1. stainless steel pneumatic actuators specification: φ85, φ108 and φ133; 2. Aluminum pneumatic actuators, specification: ZT050D, ZT063D, ZT075D, ZT088D, ZT100D, ZT115D; 3. Electric actuators, specification: HL-05, HL-10, HL-20

Actuator is fixed in the valve (by a bracket and bolts.)

The specification of manual handle as follows:

1. Pulling handle, we can supply two kinds of specification
2. Multi-position stainless steel handle can be used on the specification as follows: DN10~DN100/3A3/4"~4"/SMS19~102/DS1"~4"/ISO, IDF φ 19-φ 1083
3. Multi-position plastic handle can be used on the specification are the same as the stainless steel multi-position handle.

The handle is fixed by a bolt.

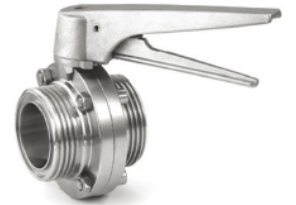

Wb型方头拉式手柄 Wb Type Square Pull Handle

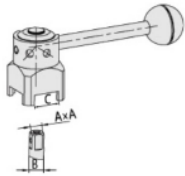

Size	A	B	C	H	
DN25-DN50	1"-2.5"	8×8	9.8	22	140
DN65	3"	10×10	13	24	140
DN80-DN100	4"	10×10	13	26	155
DN125-DN150	5"-6"	12×12	15	30	190

调节方式: 2个定位、3个定位、4个定位; 可装配所有蝶阀。
Adjusting: 2 position, 3 position, 4 position used for butterfly valve



Wd型不锈钢多位手柄 Wd Type Stainless Steel Multi-Position Handle

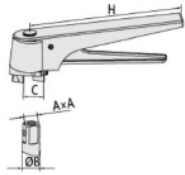

Size	AxA	B	C	H	
DN25-DN50	1"-2.5"	8×8	9.8	22	155
DN65	3"	10×10	13	24	155
DN80-DN100	4"	10×10	13	26	155

调节方式: 可通过15°位置调节开启大小, 共有十三档; 可装配所有蝶阀。
Adjusting: adjustmet 15°, 13 position used for butterfly valve



We型塑料多位手柄 We Type Plastic Multi-Position Handle

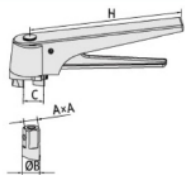

Size	A	B	C	H	
DN25-DN50	1"-2.5"	8×8	9.8	22	155
DN65	3"	10×10	13	24	165
DN80-DN100	4"	10×10	13	26	165

调节方式: 可通过15°位置调节开启大小, 共有十三档; 可装配所有蝶阀。
Adjusting: adjustmet 15°, 13 position used for butterfly valve



不锈钢气动执行器 Stainless Steel Pneumatic Actuator

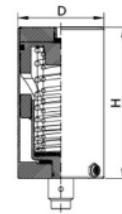

Size	D	H	可配蝶阀 Match with butterfly valve	可配蝶阀球阀 Match with butterfly-typeball valve		
85	85	150	1"-2.5"	DN20-DN65	1"-1.5"	DN20-DN40
108	108	180.5	3"-4"	DN80-DN100	2"-2.5"	DN50-DN65
133	133	250	5"-10"	DN125-DN150	3"-4"	DN80-DN100

气动装置有三种标准常开、常闭、气/气;
控制设备: 可装配信号反馈装置、电磁阀等通过这些附件可与自动化系统远程控制系统等相连接。

Three types of pneumatic device: closed, opened and closed by two air flues separately.

Control set: can match with feedback device, solenoid valve etc, with help to connect with the automatic system and remote control system.

铝制气动执行器 Aluminium Pneumatic Actuator

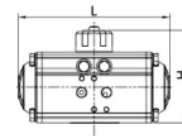

Size	L	H	可配蝶阀 Match with butterfly valve	可配蝶阀球阀 Match with butterfly-typeball valve		
ZT050D	140	89	1"-2.5"	DN20-DN32	0.75"-1"	DN15-DN25
ZT063D	159	105	2"-2.5"	DN40-DN65	1.5"-2"	DN32-DN50
ZT075D	210	122	3"-3.5"	DN80	2.5"-3"	DN65-DN80
ZT088D	248	135	4"-5"	DN100-DN125	3"-4"	DN80-DN100
ZT100D	270	147	5"	DN125	4"	DN100
ZT115D	315	165	6"	DN150		

气动装置有三种标准常开、常闭、气/气;
控制设备: 可装配信号反馈装置、电磁阀等通过这些附件可与自动化系统远程控制系统等相连接。

Three types of pneumatic device: closed, opened and closed by two air flues separately.

Control set: can match with feedback device, solenoid valve etc, with help to connect with the automatic system and remote control system.

电动执行器 Motor-Driven Actuator

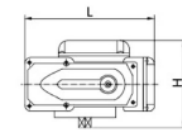

Size	L	H	H1	可配蝶阀 Match with butterfly valve	可配蝶阀球阀 Match with butterfly-typeball valve		
HL-05	157.5	115	103	1"-4"	DN20-DN100	1"-2"	DN15-DN25
HL-10	208	124	115	5"-8"	DN125-DN200	2 1/2"-3"	DN32-DN50
HL-20	280	135	109			4"	DN100

电动装置: 开关到位灯、无源接触点信号、机内智能控制、1K 5K电位计。
Electric: on-off indicator light, passive contact signal, intelligent control, 1k 5k potentiometer

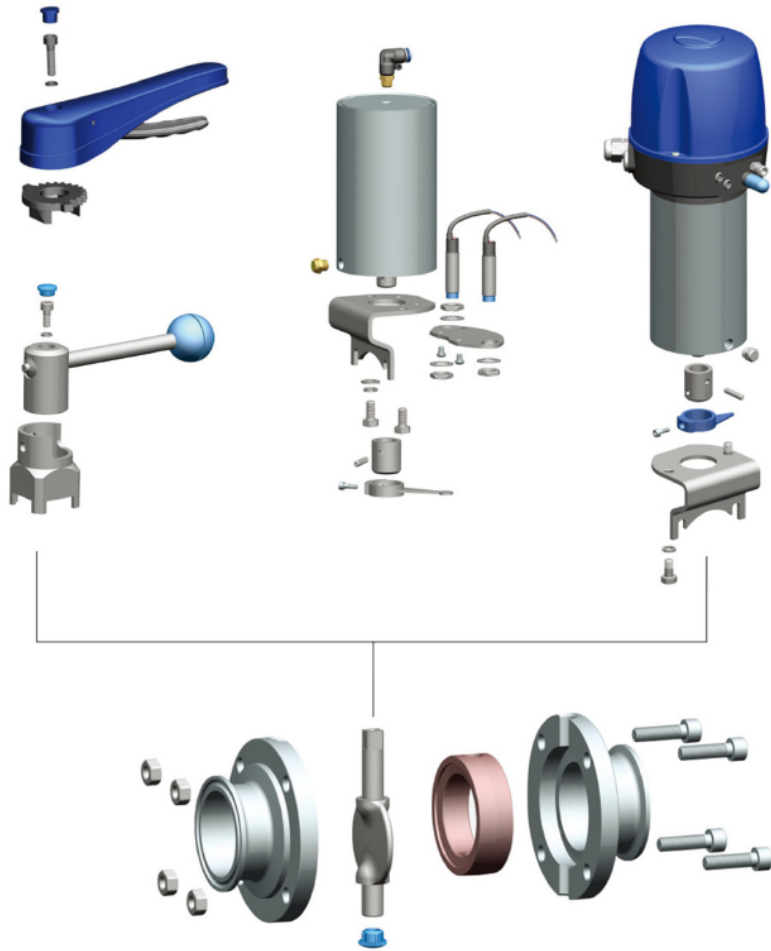

技术参数 Technical Data

金属材料 Material	与产品接触的零部件 Contact with the product components 不与产品接触的零部件 Material No contact with the product components	304L/316L(1.4306/1.4404)锻造 304L/316L(1.4306/1.4404)FoTTing 304/202(1.4301/202)	可提供材质检测报告单 Can provide material inspection report
密封材质 Sealing material	标配Standard 选配Option	硅橡胶VMQ 三元乙丙EPDM/氟橡胶(FPM)	采用进口密封材料,所有密封材质均符合FDA 117.2600 Adopt import sealing materials, with all the seal material the FDA 117.2600
压力 Pressure	工作压力Pressure of work 控制气源压力Control air pressure	0-10bar 5-8bar	
温度 Temperature	工作温度Working temperature 灭菌温度Sterilization temperature	VMQ:(-50~+180°C) EPDM:(-20~+135°C) FPM:(-30~+230°C) 150°C (MAX20min)	
表面处理 Surface treatment	内表面处理Inside surface treatment 外表面处理Surface treatment	Ra≥0.4-0.8μm Ra≥0.8-1.6μm	
连接方式 Connection	焊接罐管径The diameter welding 连接方式:焊接,快装,外螺纹,内螺纹,法兰等	焊接口:DIN 11850-2与11850-1/SM5/3A/ISO等系列 Welding mouth: DIN 11850-2 with 11850-1/SM5/3A/ISO Series etc Connection mode: welding, fast loading, male and female, flange, etc	
选配驱动 Optional driven	智能控制Brainpower 气动控制Pneumatic control	智能控制Brainpower 气动控制Pneumatic control	气动头及固定支架Pneumatic head and fixed bracket
蝶阀的体积流量:单位时间内流过蝶阀某横截面积的流体体积 Butterfly valve volume flow: flow through the butterfly valve per unit time of a cross-sectional area of the fluid volume		体积流量:立方米/小时(m ³ /h)详细技术数据请参阅(下页) Volume flow: cubic meters/hour(m ³ /h) detailed technical data please refer to the (next page)	

阀体组合形式 Body Type



焊接-焊接式
Weld-Weld series



螺纹-螺纹式
Male-Male series



快装-快装式
Clamp-Clamp series



焊接-螺纹式
Weld-Male series



焊接-快装式
Weld-Clamp series



外螺纹-接头式
Male-Liner series

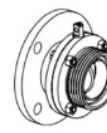

螺纹-法兰式
Male-Flange series

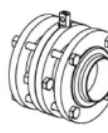

三片式法兰式
Three-piece series

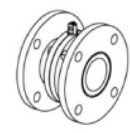

法兰-法兰式
Flange-Flange series

焊接蝶阀 Weld/Weld Butterfly Valve

3A/BS/SMS

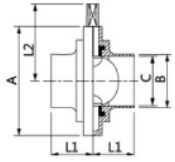

Size	A	B	C	L1	L2
1/2"	79	12.7	9.5	34	61
3/4"	79	19.05	15.8	34	61
1"	79	25.4	22.1	34	61
1.5"	85	38.1	34.8	38	64.3
2"	105	50.8	47.5	40	74.3
2.5"	112	63.5	60.2	40	77.6
3"	125	76.2	72.2	41	84.8
4"	157	101.6	97.6	44	101.7
6"	214	152.4	146.8	57	138.9

卡箍蝶阀 Clamp/Clamp Butterfly Valve

3A

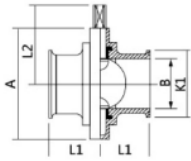

Size	A	B	K1	L1	L2
1/2"	79	9.5	25.2	34	61
3/4"	79	15.8	25.2	34	61
1"	79	22.1	50.5	33	61
1.5"	85	34.8	50.5	33	64.3
2"	105	47.5	64	35	74.3
2.5"	112	60.2	77.5	35	77.6
3"	125	72.2	91	38	84.8
4"	157	97.6	119	38	101.7
6"	213	146.8	166.8	57	138.9

螺纹蝶阀 Male/Male Butterfly Valve

SMS

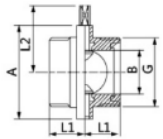

Size	A	B	G	L1	L2
DN25	79	22.5	RD40×1/6	34	61
DN38	85	35.4	RD60×1/6	38	64.3
DN51	105	48	RD70×1/6	40	74.3
DN63	112	60.2	RD85×1/6	40	77.6
DN76	125	72.1	RD98×1/6	41	84.8
DN104	157	100	RD125×1/4	50	101.7

螺纹蝶阀 Male/Male Butterfly Valve

IDF

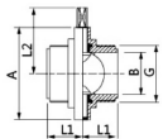

Size	A	B	G	L1	L2
1"	79	22.4	37.13×8T ACME	34	61
1.5"	85	35.1	50.65×8T ACME	38	64.3
2"	105	47.8	64.16×8T ACME	40	74.3
2.5"	112	60.5	77.76×8T ACME	40	77.6
3"	125	72	91.19×8T ACME	41	84.8
4"	157	97.6	125.9×6T ACME	44	101.7

焊接蝶阀 Weld/Weld Butterfly Valve

DIN

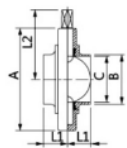

Size	A	B	C	L1	L2
Dn25	87	29	26	20	61
DN32	92	35	32	21	64.25
DN40	97	41	38	25	66.7
DN50	110	53	50	25	74.3
DN65	127	70	66	25	84.75
DN85	142	85	81	30	91.6
Dn100	162	104	100	35	101.75

三片式蝶阀 Weld/Weld Butterfly Valve

DIN

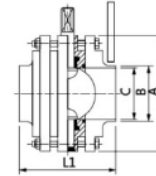

Size	A	B	C	L1
DN25	32	51.3-RD52×1/6	26	61
DN32	32	57.3-RD58×1/6	32	64.25
DN40	36	64.3-RD65×1/6	38	66.7
DN50	36	77.3-RD78×1/6	50	74.3
DN65	38	94.3-RD95×1/6	66	84.75
DN85	50	109-RD110×1/4	81	91.6
DN100	52	129-RD130×1/4	100	101.75

两边法兰式蝶阀 Two Side Flange Butterfly Valve

DIN

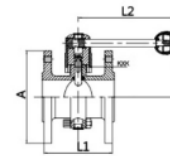

Size	A	L1	L2	H	KxK
DN25	115	94	126	80	8×8
DN32	135	102	126	80	8×8
DN40	145	110	126	86	8×8
DN50	160	112	133	106	10×10
DN65	180	124	144	115	10×10
DN85	195	130	160	122	11×11
DN100	215	152	160	132	11×11
DN125	245	178	220	147	11×11
DN150	280	198	220	162	11×11

对夹式蝶阀 Wafer Butterfly Valve

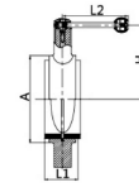

Size	A	L1	L2	H
DN40	85	38	124	122
DN50	95	39	130	127
DN65	107	42	130	133
DN85	125	43	140	142
DN100	156	46	158	158
DN125	180	55	220	160
DN150	205	55	220	170
DN200	250	60	280	210

单圆法兰单螺纹蝶阀 Single Round Flange Single Threaded Butterfly Valve

DIN

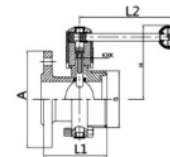

Size	A	G	L1	L2	H	KxK
DN25	115	RD52×1/6	80	126	80	8×8
DN32	135	RD58×1/6	86	126	80	8×8
DN40	145	RD65×1/6	92	126	86	8×8
DN50	160	RD78×1/6	94	133	106	10×10
DN65	180	RD95×1/6	104	144	115	10×10
DN85	195	RD110×1/4	110	160	122	11×11
DN100	215	RD130×1/4	130	160	132	11×11
DN125	245	RD160×1/4	154	220	147	11×11
DN150	280	RD190×1/4	174	220	162	11×11



Sanitary Check Valves

卫生级止回阀系列



卫生级止回阀 (RZ) Sanitary Check Valve (RZ)

应用:

该类型止回阀用于不锈钢管道系统内, 以达到防止流体回流的目的。

Application:

This type of check valves are used to stainless steel pipe system, in order to prevent the fluid flowing back.

工作原理:

止回阀是指依靠介质本身流动而自动开、闭阀瓣的一类阀门, 当阀杆下部的压力超过阀杆上面的压力以及弹簧力时, 止回阀阀瓣就会开启; 当阀杆上下压力平衡时, 止回阀就会关闭, 从而达到介质在管道的单向流动, 阻止液体的倒流, 防止事故发生。

Work Principle:

Check valve is a type of valve which open or close the valve disc rely on the medium flow itself. The check valve disc will open when the pressure of stem bottom exceed the stem above and the spring. The check valve disc will close when the two pressure are equalled. So that the flow goes one way in the pipeline, and prevent the fluid flowing back, avoid the accidents.

材料:

钢制部件: 不锈钢304、不锈钢316L。
密封圈: 硅橡胶 (VMQ) 氟橡胶 (FPM)
三元乙丙 (EPDM)

Material:

Steel parts: 304 stainless steel, stainless steel 316L.
Seal: silicone rubber material (vmq) fluoroelastomer (fpm), epdm)



技术数据

若止回阀被安装在一根垂直的管道内, 开启阀门所需的压力大约为6Kpa, 最大输送物料压力为1000Kpa, 使用温度范围为-10°C-140°C。

Technical Data:

If the check valves are installed in a vertical pipe, it needd approximately equal pressure 6Kpa to open, maximum pressure for conveying material is 1000Kpa, Using temperature scope for -10°C-140°C.

标注设计:

有各种标准的止回阀系列可向客户提供, 即用于DIN标准系列, 3A标准系列, SMS标准系列, ISO/IDF标准系列, BS/RJT标准系列, ASME/BPE等标准系列。

止回阀的阀体分为两个部分, 通过卡箍组装在一起, 并用一种特殊密封圈进行密封。一个导向圆片和四个导向杆用来引导弹簧, 并配有O型密封圈的阀芯。该类止回阀系列具有焊接式, 卡箍式与外螺纹式连接端口, 可适配各种管道连接。

Standard Design:

Various standards of valves can be provided to clients: DIN, 3A, SMS, ISO/IDF, BS/RJT, ASME/BPE etc.

The body of Check valve is divided into two parts, they are together by the clamp, and also use a special gasket for seal. A guide discs and four guide bar are used to guide the spring, which is equipped with spindle with O type seal. This type of check valve: weld, clamp, and male. which are suitable for all kinds of pipeline connections.

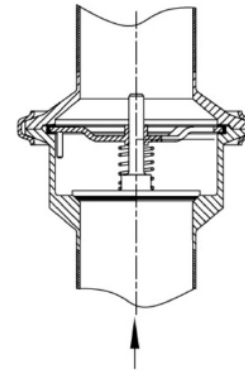

垂直放置显示了最佳内置情况。另外也可水平放置。四个圆锥腿确保了良好的指导线路。

90° rotation.
Shows the optimal built-in situation. Other positions permitted are e.g. horizontal. The four guide legs of the valve cone ensures good alignment.





处理能力/压力降对比图
Pressure Drop/Capacity Diagram

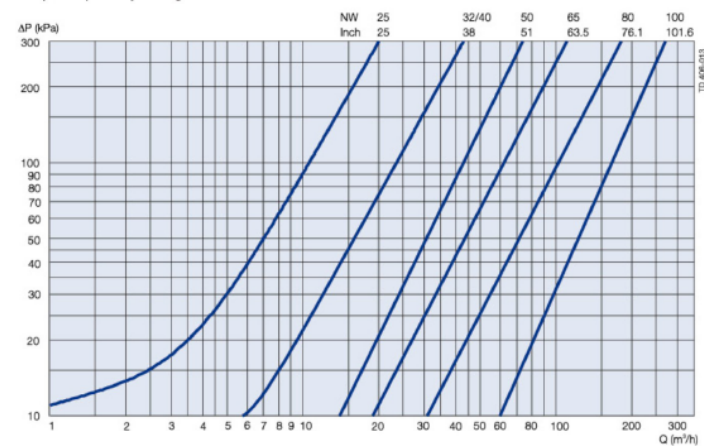

Note!
For the diagram the following applies:
Medium: Water (20°C).
Measurement: In accordance with VDI 2173.

注意!
这些曲线图示数据的测定系基于:
介质:水(水温20°C)
测量:符合VDI 2173.

技术参数 Technical Data

金属材料 Material	与产品接触的零部件 Contact with the product components	304L/316L(1.4306/1.4404)锻造 304L/316L(1.4306/1.4404)FoTing	可提供材质检测报告单 Can provide material inspection report
	不与产品接触的零部件 Material No contact with the product components	304/202(1.4301/202)	
密封材质 Sealing material	标配Standard 选配Option	硅橡胶VMQ 三元乙丙EPDM/氟橡胶(FPM)	采用进口密封材料,所有密封材料均符合FDA 117.2600 Adopt import sealing materials, with all the seal material the FDA 117.2600
压力 Pressure	工作压力Pressure of work	0~10bar	
温度 Temperature	工作温度Working temperature	VMQ: [-50~+180°C] EPDM: [-20~+135°C] FPM: [-30~+230°C]	
	灭菌温度Sterilization temperature	150°C (MAX20min)	
表面处理 Surface treatment	内表面处理Inside surface treatment	Ra ≥ 0.4-0.8µm	
	外表面处理Surface treatment	Ra ≥ 0.8-1.6µm	
连接方式 Connection	焊接端管径The diameter welding	焊接口: DIN 11850-2与11850-1/SMS/3A/ISO等系列 Welding mouth: DIN 11850-2 with 11850-1/SMS/3A/ISO Series etc	
	连接方式: 焊接、快装、外螺纹、内螺纹、法兰等	Connection mode: welding, fast loading, male and female, flange, etc	

止回阀的体积流量: 单位时间内流过止回阀某横截面积的流体体积
Check valve's volume flow: flow through the valve per unit time of a cross-sectional area of the fluid volume

体积流量: 立方米/小时 (m³/h) 详细技术参数请参阅(上图表)
Volume flow: cubic meters/hour (m³/h) detailed technical data, refer to (on the chart)

焊接式止回阀Welded Check Valve

DIN

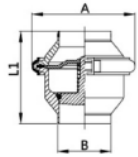

Size	A	B	L1
DN15	87	19	75
DN20	87	23	75
DN25	87	29	75
DN32	87	35	75
DN40	87	41	75
DN50	100	53	80
DN65	130	70	110
DN80	155	85	115
DN100	165	104	120

卡箍式止回阀Clamped Check Valve

DIN

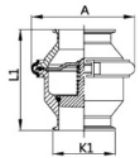

Size	A	K1	L1
DN15	87	50.5	105
DN20	87	50.5	105
DN25	87	50.5	105
DN32	87	50.5	105
DN40	87	50.5	105
DN50	100	64	110
DN65	130	91	145
DN80	155	106	150
DN100	165	119	155

螺纹式止回阀Threaded Check Valve

DIN

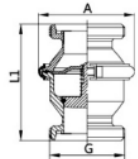

Size	A	G	L1
DN15	87	RD34×1/8	111
DN20	87	RD44×1/6	115
DN25	87	RD52×1/6	117
DN32	87	RD58×1/6	117
DN40	87	RD65×1/6	117
DN50	100	RD78×1/6	122
DN65	130	RD95×1/6	156
DN80	155	RD110×1/4	167
DN100	165	RD130×1/4	176

焊接式止回阀Welded Check Valve

SMS

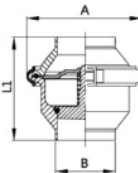

Size	A	B	L1
19	87	19.1	75
25	87	25.4	80
32	87	31.8	80
38	87	38.1	80
51	100	50.8	90
63	115	63.5	102
76	130	76.2	102
89	155	89	115
102	165	101.6	120

球型止回阀Ball-Type Check Valve

DIN

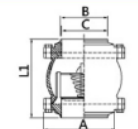

Size	A	B	C	L1
DN40	100	41	38	115
DN50	110	53	50	125
DN65	130	70	66	135
DN80	146	85	81	145
DN100	166	104	100	155

卡箍式止回阀Clamped Check Valve

SMS

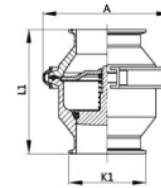

Size	A	K1	L1
19	87	50.5	100
25	87	50.5	100
32	87	50.5	100
38	87	50.5	100
51	100	64	115
63	115	77.5	127
76	130	91	127
89	155	106	150
102	165	119	155

焊接式止回阀Welded Check Valve

3A

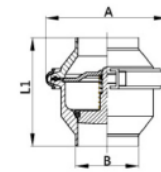

Size	A	B	L1
1/2"	87	12.7	76.5
3/4"	87	19.1	76.5
1"	87	25.4	76.5
1 1/2"	87	38.1	76.5
2"	100	50.8	87.9
2 1/2"	115	63.5	96.5
3"	128	76.2	116.5
4"	164	101.6	156.5

卡箍式止回阀Clamped Check Valve

3A

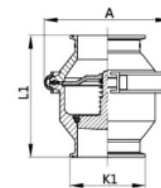

Size	A	K1	L1
1/2"	87	25.4	105
3/4"	87	25.4	105
1"	87	50.5	105
1 1/2"	87	50.5	105
2"	100	64	110
2 1/2"	115	77.5	135
3"	130	91	150
4"	165	119	155

焊接式止回阀Welded Check Valve

ISO/IDF

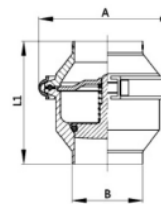

Size	A	B	L1
19	87	19	75
25	87	25.4	75
32	87	32	75
38	87	38.1	75
45	100	45	75
51	100	50.8	80
57	100	57	80
63	115	63.5	100
76	130	76.2	115
89	155	88.9	115
102	165	101.6	120
108	165	108	120



Sanitary Diaphragm Valves

卫生级隔膜阀系列



卫生级隔膜阀 (FT) Sanitary Diaphragm Valve (FT)

应用:

隔膜阀是一款卫生型的隔膜阀系列, 广泛适用于卫生级的酿酒、乳制品以及饮料等食品工业以及无菌工况的制药领域, 实现对管道流体的控制和开/关任务。

Application:

diaphragm valve is a series of sanitary diaphragm valve, it is widely used on wine, dairy products, beverage, foodstuff industry, pharmacy etc. achieving the requirement of control and open/close for the pipeline system.

工作原理:

隔膜阀常规状态下为封闭状态, 此时膜片紧贴阀体的内腔, 关闭着管道流体通向路径。当隔膜阀需要清洗任务或需要开启任务时, 通过手动旋转手轮或驱动气动控制执行装置来带动阀杆向上运动, 球形膜片随之向上弯曲, 从而使阀门形成导通状态, 则可实现清洗和开启的目的。其中膜片把下部阀体内腔和上部阀盖内腔隔开, 使位于膜片上部的阀杆、阀芯等零件不受介质的腐蚀, 省去了填料密封结构, 而且不会产生介质泄漏。优化的阀体设计, 使清洗液完全排泄, 不会形成滞留现象。

材料:

钢质部件: 不锈钢304、不锈钢316L。
密封件: EPDM+PTFE (三元乙丙+聚四氟乙烯) 此密封件均采用进口密封材料 (均符合FDA17.2600标准)。用特有技术, 将一个连接螺栓与EPDM/PTFE完美结合成一体密封部件, 此密封部件与介质接触部位的PTFE材质具有良好的耐寒性 (-25℃) 极好的耐热性 (+250℃) 对各种化学制剂有良好的耐受性以及对流体具有极好的耐磨性!



Work Principle:

The diaphragm is close under normal state, and that moment the diaphragm clung to the valve body cavity, and closing off the flow path through the pipeline. When the diaphragm valve have the requirement to clean or open, the valve stem moves upwards according to the manual or pneumatic actuator equipment, spherical diaphragms naturally bend upwards, so that the valve is open and reach the requirement of clean and open. The diaphragm make the lower body cavity and the upper chamber separated from the valve cover, so that the stem at the top of the diaphragm, disc media and other parts from corrosion, eliminating the need for packing structure, and no media leaks. The optimize valve body made the cleaning liquid flow out totally, so that don't have any entrapment.

Material:

Steel components: stainless steel 304, stainless 316L
Seal: EPDM + PTFE the seals are imported seal material (which conform to the FDA17.2600 standard). With unique technology, will be a bolt coupling nut with EPDM/PTFE perfect combination into a whole sealing parts, the sealing parts contact with the media of the parts of the PTFE material has good cold resistance (-25 °C) excellent heat-resistance (+ 250 °C) of all sorts of chemical preparation is well tolerated and excellent wear resistance to flow.

标准设计

有各种标准的隔膜阀系列可向客户提供, 即用于DIN标准系列, 3A标准系列, SMS标准系列, ISO/DF标准系列, BS/RJT标准系列, ASME/BPE等标准系列。

该阀门的组成部件包括: 一个执行装置, 膜片和阀体, 是用螺栓及螺母组装在一起, 整个阀门的组装都是精心细致的。其执行装置包括手动和气动, 膜片具有各种软硬程度的人造橡胶, 阀体为两通或三通阀。

现有的隔膜阀系列规格有: 卡式隔膜阀、焊接式隔膜阀、T型三通式隔膜、U型三通式隔膜阀等系列隔膜阀。

Standard Design:

Various standards of valves can be provided to clients: DIN, 3A, SMS, ISO/IDF, BS/ RJT, ASME/BPE etc.

The parts of valves: an actuator, diaphragm and body which assemble together with bolts and nuts. The entire valve assembly in meticulously. The actuator can be manual and pneumatic, the diaphragm made of artificial rubber which can have all kinds of soft and hard degree. The body can be two way or three way.

The connection of the diaphragm as follows: clamp, weld, T-type tee, U type tee etc.

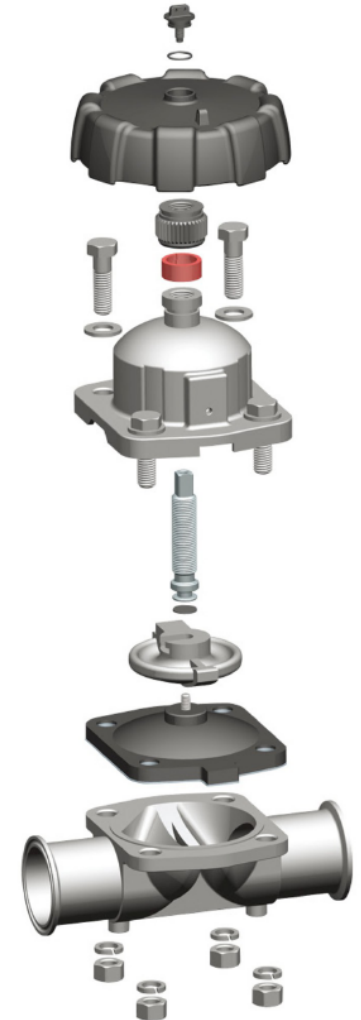

技术参数 Technical Data

金属材质 Material	与产品接触的零部件 Contact with the product components	304L/316L(1.4306/1.4404)锻造 304L/316L(1.4306/1.4404)	可提供材质检测报告单 Can provide material inspection report
	不产品接触的零部件 Material No contact with the product components	FoFTing 304/202(1.4301/202)	
密封材质 Sealing material	标配Standard	EPDM+PTFE	采用进口密封材料, 所有密封材质均符合FDA 117.2600 Adopt import sealing materials, with all the seal material the FDA 117.2600
	选配Option	硅橡胶VMQ	
压力 Pressure	工作压力Pressure of work	0~10bar	
	控制气源压力Control air pressure	5~8bar	
温度 Temperature	工作温度Working temperature	VMQ:(-50~+180°C) EPDM:(-20~+135°C) FPM:(-30~+230°C)	
	灭菌温度Sterilization temperature	150°C (MAX20min)	
表面处理 Surface treatment	内表面处理Inside surface treatment	Ra ≥ 0.4-0.8μm	
	外表面处理Surface treatment	Ra ≥ 0.8-1.6μm	
连接方式 Connection	焊接管径The diameter welding	焊接口: DIN 11850-2与11850-1/SMS/3A/ISO等系列 Welding mouth: DIN 11850-2 with 11850-1/SMS/3A/ISO Series etc	
	连接方式: 焊接、快装、外螺纹、由任、法兰等	Connection mode: welding, fast loading, Union, flange, etc	
气动控制 Pneumatic control	气动头及固定支架Pneumatic head and fixed bracket		

隔膜阀最优安装角度示意图 Optimal Installation Angle Diagram

无菌隔膜阀根据其结构特点: 推荐15~30度角安装 (根据不同的规格而定), 有利于阀门清洗后完全排泄, 不易造成液体滞留阀门内部。
According to the structure feature, fifteen thirty degree is optimal, which makes for complete drain after cleaning and keep no residue.

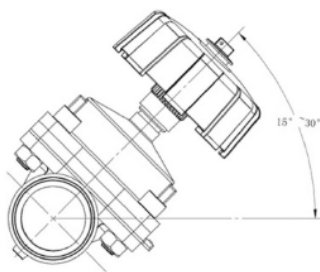

(C) Body & Diaphragm Body

福特所有的隔膜阀皆为锻造加工, 其材质为316L。阀体外部处理包括了喷砂及电解处理二种, 其中电解处理可提高耐腐蚀性能, 外观更显光亮; 阀体二端所连接尺寸更采用CNC高精度数控加工; 阀体内部则由专业抛光技术所精抛而成。福特更可以根据客户的要求设计多重通位的阀体。

All the materials of the body is 316L & FoFTed. The surface can be divided into two kinds-Sand Blasted & Electrolytic Polished (EP). With the external body Electrolytic Polished. It improves the corrosion resistance and makes the external appearance more bright and beautiful as well. The Body ends connection sizes are processed by high precision CNC. Then, the body's inside is polished by professional polishing technology. FOGO Group also can design more bodies according to the clients' requires.



Diaphragm

福特膜片均符合卫生/制药级标准并通过美国FDA之认证, 更具有耐高温、使用寿命长、抗腐蚀性、适用性广泛等特点。

All the diaphragms in Group meet sanitary and Pharmaceutical Standards and they have gained Certificate of FDA. The Diaphragms are high temperature resistant and strong corrosion resistance; they are of long service life and are widely used.



Internal Structure of the Diaphragm



卫生级气动焊接式隔膜阀 Sanitary Pneumatic Welded Diaphragm Valve

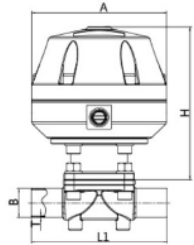

DIN	Size			A	L1	H
	3A	SMS	ISO			
DN20	3/4"	19	Φ19	126	108	146.2
B×T	B×T	B×T	B×T			
22×1.5	19.1×1.65	19.1×1.5	19.1×1.5			
DN25	1"	25	Φ25	126	118	146.2
B×T	B×T	B×T	B×T			
28×1.5	25.4×1.65	25.4×1.5	25.4×1.5			
DN32	1 1/4"	32	Φ32	126	127	146.2
B×T	B×T	B×T	B×T			
34×1.5	31.8×1.65	31.8×1.5	31.8×1.5			
DN40	1 1/2"	38	Φ38	126	146	146.2
B×T	B×T	B×T	B×T			
40×1.5	38.1×1.65	38.1×1.5	38.1×1.5			
DN50	2"	51	Φ51	126	190	146.2
B×T	B×T	B×T	B×T			
52×1.5	50.8×1.65	50.8×1.5	50.8×1.5			
DN65	2 1/2"	63	Φ63	126	216	146.2
B×T	B×T	B×T	B×T			
70×2	63.5×1.65	63.5×2	63.5×2			

卫生级气动快装式隔膜阀 Sanitary Pneumatic Clamped Diaphragm Valve



DIN	Size			L1	A	H
	3A	SMS	ISO			
DN20	3/4"	19	Φ19	108	126	146.2
B 22	B19.1	B19.1	B19.1			
K150.5	K125.4	K125.4	K125.4			
DN25	1"	25	Φ25	118	126	146.2
B 28	B25.4	B25.4	B25.4			
K150.5	K150.5	K150.5	K150.5			
DN32	1 1/4"	32	Φ32	127	126	146.2
B 34	B31.8	B31.8	B31.8			
K150.5	K150.5	K150.5	K150.5			
DN40	1 1/2"	38	Φ32	146	126	146.2
B 40	B38.1	B38.1	B31.8			
K150.5	K150.5	K150.5	K150.5			
DN50	2"	51	Φ51	190	126	146.2
B 52	B50.8	B50.8	B50.8			
K164	K164	K164	K164			
DN65	2 1/2"	63	Φ63	216	126	146.2
B 70	B63.5	B63.5	B63.5			
K191	K177.5	K177.5	K177.5			

卫生级手动焊接式隔膜阀 Sanitary Manual Welded Diaphragm Valve

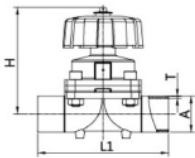

Size	L1	A	H	T
DN10	108	12	93.5/102.5	1.5
DN15	108	18	93.5/102.5	1.5
DN20	118	22	111.5/122	1.5
DN25	127	28	111.5/122	1.5
DN32	146	34	144.5/160	1.5
DN40	146	40	144.5/160	1.5
DN50	190	52	167/190	1.5
DN65	216	70	199/228	2

卫生级手动卡箍式隔膜阀 Sanitary Manual Clamped Diaphragm Valve

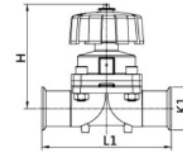

Size	L1	K1	H
DN10	108	25	93.5/102.5
DN15	108	34	93.5/102.5
DN20	118	50.5	111.5/122
DN25	127	50.5	111.5/122
DN32	146	50.5	144.5/160
DN40	146	50.5	144.5/160
DN50	190	64	167/190
DN65	216	91	199/228

卫生级手动T型三通隔膜阀 Sanitary Manual T-Type Three-Way Diaphragm Valve

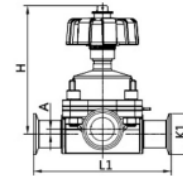

Size	L1	K1	A	H
DN10	108	25	6	93.5/102.5
DN15	108	34	6	93.5/102.5
DN20	118	50.5	6	111.5/122
DN25	127	50.5	6	111.5/122
DN32	146	50.5	6	144.5/160
DN40	146	50.5	6	144.5/160
DN50	190	64	6	167/190
DN65	216	91	6	199/228

卫生级手动焊接式隔膜阀 Sanitary Manual Welded Diaphragm Valve

3A

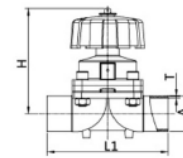

Size	L1	A	H	T
1/2"	108	12.7	93.5/102.5	1.65
3/4"	108	19.1	93.5/102.5	1.65
1"	118	25.4	111.5/122	1.65
1 1/4"	127	31.8	144.5/160	1.65
1 1/2"	146	38.1	144.5/160	1.65
2"	190	50.8	167/190	1.65
2 1/2"	216	63.5	199/228	1.65

卫生级手动卡箍式隔膜阀 Sanitary Manual Clamped Diaphragm Valve

3A

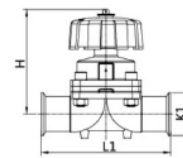

Size	L1	K1	H
1/2"	108	25.4	93.5/102.5
3/4"	108	25.4	93.5/102.5
1"	118	50.5	111.5/122
1 1/4"	127	50.5	144.5/160
1 1/2"	146	50.5	144.5/160
2"	190	64	167/190
2 1/2"	216	77.5	199/228



Sanitary Ball Valves

卫生级球阀系列



卫生级球阀系列 Sanitary Ball Valves

应用:

该球阀根据3A、ASME、BPE标准设计,主要应用于生物制药、食品饮料、酿酒、化工等工业领域。

Application:

The ball valve according to 3A, ASME, BPE standard design, mainly used in bio-pharmaceuticals, food and beverage, wine, chemical and other industrial fields.

技术特点:

全包式球阀设计,无滞留、高洁净,满足CIP、SIP杀菌和清洗要求、耐高温150°C,压力25bar,自动补偿密封设计,具有扭矩小,寿命长等特点,正常开关10万次以上,可配置各种执行结构,如电动头、卧式气动头、不锈钢立体气动,手动手柄,还可以加装控制单元、定位器、位置传感器等,也可装自动控制系统。

Technical Characteristics:

Full-package ball valve design, no retention, high clean, to meet the CIP SIP sterilization and cleaning requirements, high temperature 150°C, pressure 25bar, automatic compensation seal design, with torque, long life and other characteristics, the normal switch 100,000 times, Can be equipped with a variety of executive structures, such as the electric head, horizontal pneumatic head, stainless steel three-dimensional pneumatic, the key manual handle, you can also install the control unit, positioner, position sensor, can also be installed automatic control system.

表面处理:

所有的表面CNC, 0.8m, 达到RA0.4cm, 电抛光可达到0.25cm。

Surface Finish:

All the surface CNC, 0.8m, to RA0.4cm, electrical polishing up to 0.25cm.

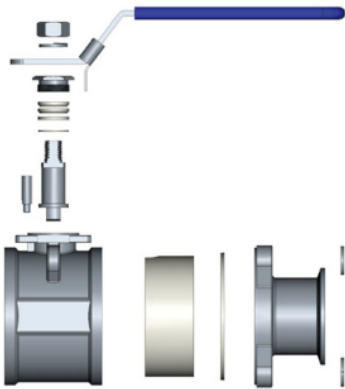

一片式球阀One-Piece Ball Valve

3A

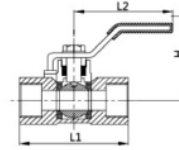

Size	L1	H	L2
1/4"	40	28	70
3/8"	45	30	70
1/2"	55	34	90
3/4"	60	38	90
1"	70	50	110
1 1/4"	78	57	120
1 1/2"	83	60	130
2"	100	65	130

三片式卡箍球阀Three-Piece Clamped Ball Valve

3A

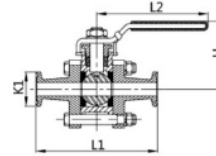

Size	K1	L1	H	L2
1/4"	25.2	90	67	130
3/4"	25.2	102	70	130
1"	50.5	114	76	163
1 1/2"	50.5	140	91	189
2"	64	157.5	98	189
2 1/2"	77.5	198	140	300
3"	91	220	161	250
4"	119	243.5	180	330

三片式焊接式球阀Three-Piece Welded Ball Valve

3A

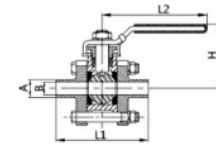

Size	A	B	L1	L2	H
1/4"	12.7	9.4	90	130	67
3/4"	19.05	15.8	102	130	70
1"	25.4	22.1	114	163	76
1 1/2"	38.1	34.8	140	189	91
2"	50.8	47.5	157.5	189	98
2 1/2"	63.5	60.2	198	300	140
3"	76.2	72.2	215	300	148
4"	101.6	97.4	243.5	330	180

二片式卡箍球阀 Two-Piece Clamped Ball Valve

SMS/3A/ISO

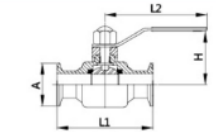

Size	A	L1	L	H	
3/4"	19	50.5	95	105	55
1"	25	50.5	115	105	55
1 1/4"	32	50.5	120	130	65
1 1/2"	38	50.5	140	150	65
2"	51	64	165	160	85

卡箍式无滞球阀Clamped Non-Retention Ball Valve

SMS/3A/ISO

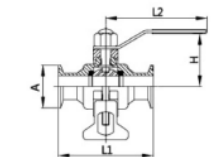

Size	A	B	H	L	
3/4"	19	90.0	25.4	65.0	105.0
1"	25	110.0	50.5	70.0	105.0
1 1/4"	32	120.0	50.5	80.0	130.0
1 1/2"	38	140.0	50.5	80.0	150.0
2"	51	164.0	64.0	85.0	160.0
2 1/4"	57	170.0	77.5	110.0	180.0
2 1/2"	63	180.0	77.5	110.0	180.0

三片式电动球阀 Three-Piece Electric Ball Valves

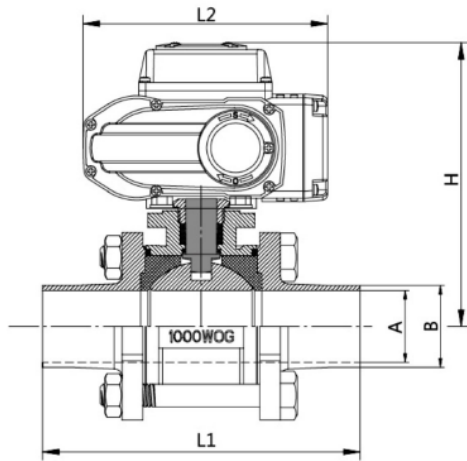

Size	A	B	L1	L2	H	执行器型号 Actuator type
1/2"	9.4	12.7	90	178	171	FY-05
3/4"	15.8	19.1	102	178	179	FY-05
1"	22.1	25.4	114	178	182	FY-05
1 1/2"	34.8	38.1	140	178	195	FY-05
2"	47.5	50.8	157.5	210	225	FY-05
2 1/2"	60.2	63.5	198	210	262	FY-10
3"	72.2	76.2	230	210	262	FY-30
4"	97.4	101.6	242	309	286.5	FY-30

三片式气动球阀 Three-Piece Pneumatic Ball Valves

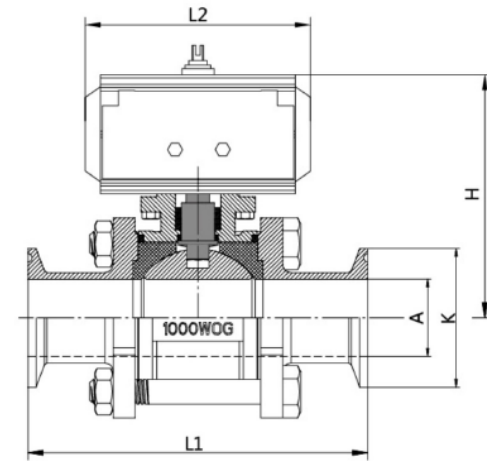

Size	A	K	L1	L2	H	气缸型号 Cylinder type
1/2"	9.4	25.2	90	136	123	AT-40
3/4"	15.8	25.2	102	136	130	AT-50
1"	22.1	50.5	114	153.5	149	AT-63
1 1/2"	34.8	50.5	140	204.6	177.5	AT-75
2"	47.5	64	157.5	204.6	186	AT-83
2 1/2"	60.2	77.5	198	242	238	AT-92
3"	72.2	91	230	278.5	238	AT-105
4"	97.4	119	242	312	303	AT-140

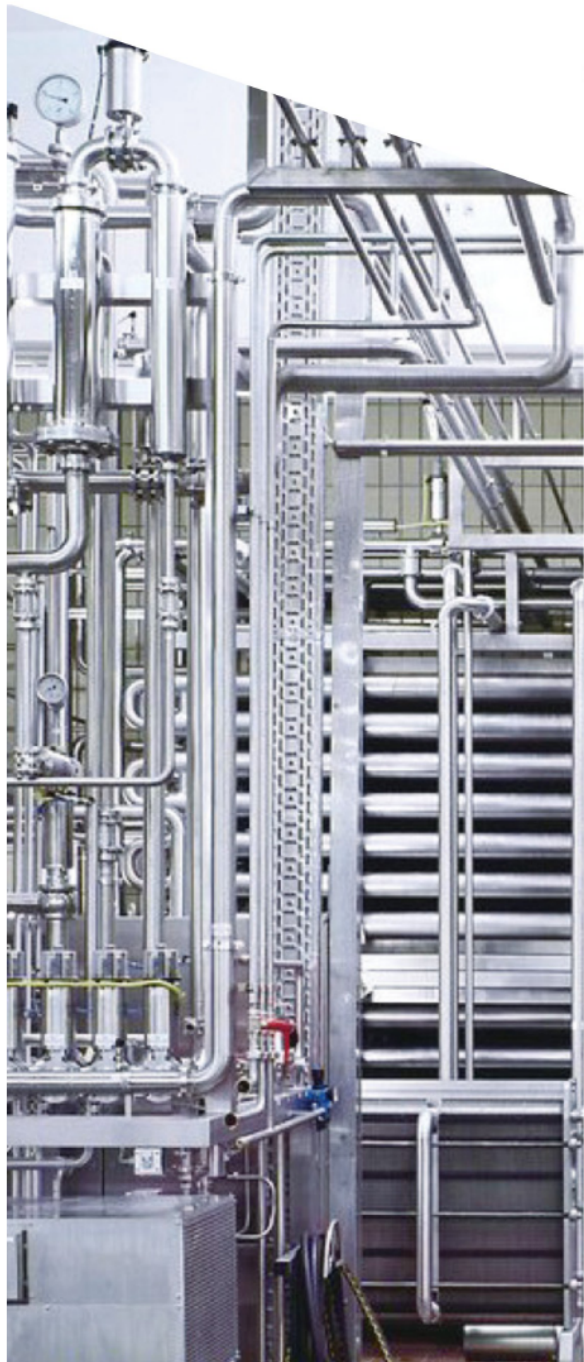

Sanitary Filter

卫生级过滤器系列



卫生级过滤器 Sanitary Filter

应用:

过滤器系列是一种卫生级过滤器，主要用于过滤液体中自带的固体颗粒，保护泵、仪器仪表和其它设备的正常工作。因其结构合理、过滤以及密封能力强、压损小和维修方便等特点，广泛应用于酿酒、饮料、制药和乳制品等领域。

Application:

Filter series is a kind of sanitary filter, mainly used for filtering liquid with solid particles, protect the pump, instruments and other devices to work properly. Because of its reasonable structured, filtration and seal ability strong, pressure loss of small and easy maintenance and other characteristics, widely used in wine, beverage, pharmaceutical, etc.

工作原理:

当带有较大固体颗粒或杂质的介质通过过滤器时，这些较大的固体颗粒和杂质会被过滤而停留在一定规格的滤芯内，从而阻止了这些固体颗粒和杂质进入后续管道，过滤后的介质则由出口流出，达到使用要求。

Work Principle:

When with laTter solid particles or impurity of media through the filter, these laTter solid particles and impurities will be filtered and stay in certain specification filter inside, thus preventing the solid particles and impurities into subsequent pipes, filtered medium cFOGOion by export outflow, achieve the requirement.



标准设计:

能提供“Y”型过滤器、焊接以及螺纹、快装等连接方式的直通过滤器。当滤芯需要清洗或滤芯损坏时：“Y”型过滤器只需取下由任接头，取出滤芯，便可清洗或更换；焊接直通过滤器需被拆下，然后将滤芯取出，清洗或更换，从新安装好方可使用。

Standard Design:

can provide Y type filter, welding and thread, clamp etc connection mode through filters. When filter need cleaning or filter damage: Y type filter only take down by any joint, remove filter core, it can be cleaned or change, Welding straight-through filters that need to be removed, then remove cores, clean or replace, reinstall the product can be used.

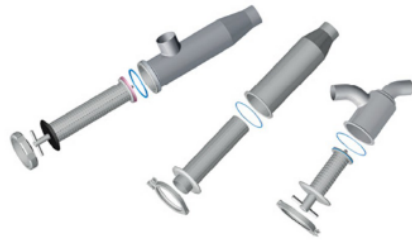
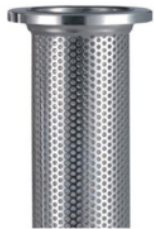

材料:

钢质部件:304或316L
密封件:EPDM (标配) 或NBR (选配)

Material:

Steel parts: 304 or 316L
Seal: EPDM (with standard) or NBR (optional)

技术参数:

工作压力:0~10bar
工作温度:-20~+135°C (密封件为EPDM时)
温度范围:-10°C至250°C

Technical parameter:

Work pressure: 0~10 bar
Work temperature: -20~+135°C (EPDM as seal)
Temperature range: -10°C to 250°C

筛网:金属网Screen: Metal Mesh

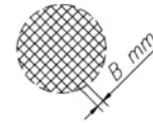

网孔目数 Mesh	B(mm)	有效面积 Useful surface (%)
30	0.55	48
40	0.40	46
60	0.30	52.6
80	0.20	42
100	0.15	36.2
165	0.10	45.4

筛网:多孔板Screen: Perforated Plate



A(mm)	有效面积 Useful surface (%)
0.5	15
1	28
1.5	33
2	30
3	33
5	46



焊接式直通过滤器Welded Straight Strainer

DIN

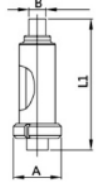

Size	A	B	L1
DN25	95	28	306
DN32	110	34	306
DN40	110	40	306
DN50	110	52	406
DN65	127	70	503
DN80	148	85	561
DN100	178	104	662

卡箍式直通过滤器Clamped Straight Strainer

DIN

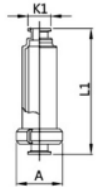

Size	A	L1	K1
DN25	95	306	50.5
DN32	110	306	50.5
DN40	110	306	50.5
DN50	110	406	64
DN65	127	503	77.5
DN80	148	561	91
DN100	178	662	119

焊接角式过滤器Welded Angle-Type Strainer

DIN

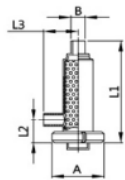

Size	A	B	L1	L2	L3
DN25	95	28	306	60	70
DN32	110	34	306	60	70
DN40	110	40	306	80	70
DN50	110	52	406	100	72
DN65	127	70	503	120	85
DN80	148	85	561	140	96
DN100	178	104	662	160	117

螺纹角式过滤器 Threaded Angle-Type Strainer

DIN

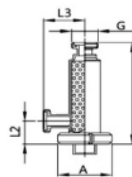

Size	A	G	L1	L2	L3
DN25	95	RD52×1/6	306	70	60
DN32	110	RD58×1/6	306	70	60
DN40	110	RD65×1/6	306	70	80
DN50	110	RD78×1/6	406	72	100
DN65	127	RD95×1/6	503	85	120
DN80	148	RD110×1/4	561	96	140
DN100	178	RD130×1/4	662	117	160

焊接角式过滤器Welded Angle-Type Strainer

3A

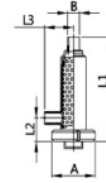

Size	A	B	L1	L2	L3
1"	95	25.4	306	60	70
1 1/4"	110	32	306	60	70
1 1/2"	110	38.1	306	80	70
2"	110	50.8	406	100	72
2 1/2"	127	63.5	503	120	85
3"	148	76.2	561	140	96
4"	178	101.6	662	160	117

Y型过滤器Y Type Strainer

DIN

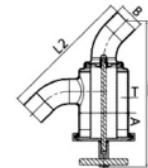

Size	A	B		L1	L2	T
		1	2			
DN25	102	28	29	275	204	1.5
DN32	102	34	35	288	226	1.5
DN40	102	40	41	282	242	1.5
DN50	102	52	53	312	280	1.5
DN65	114	70	-	390	362	2
DN80	114	85	-	405	406	2
DN100	154	100	-	565	460	2

螺纹式Y型过滤器 Threaded Y-Type Strainer

DIN

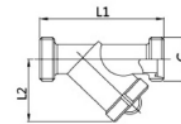

Size	L1	L2	G
DN25	125	95	RD52×1/6
DN32	140	104	RD58×1/6
DN40	165	110	RD65×1/6
DN50	195	140	RD78×1/6
DN65	230	185	RD95×1/6
DN80	280	220	RD110×1/4
DN100	340	248	RD130×1/4

焊接式Y型过滤器Welded Y-Type Strainer

DIN

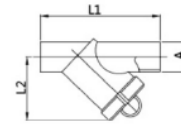

Size	A	L1	L2
DN25	28	125	95
DN32	34	140	104
DN40	40	165	110
DN50	52	195	140
DN65	70	230	185
DN80	85	280	220
DN100	104	340	248

卫生呼吸器 Sanitary Rebreather

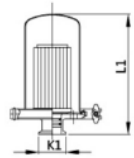

Size	L1	K2
1"	180	50.5
1.5"	180	50.5
2"	180	64

地漏 Floor Drain

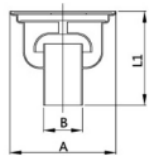

Size	A	B	L1
1"	130	25	80
1.5"	130	38	80
2"	195	51	100
2.5"	195	63	100
3"	230	76	130
4"	230	100	130

过滤器 Strainer

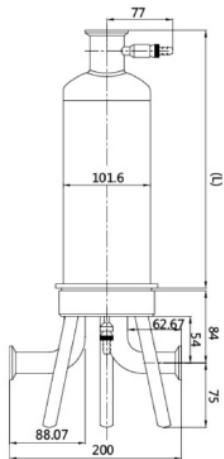

高度	L	滤芯接口
5"	233(185)	226(7#)
10"	360	226(7#)
20"	614	226(7#)
30"	868	226(7#)

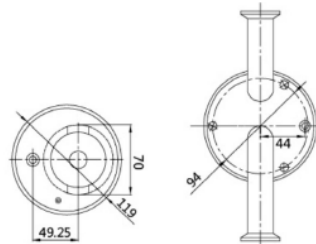

卫生级无菌采样阀 Sanitary Aseptic Sample Valve

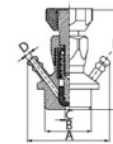

Size	A	B	C	D	E
Dn15	75	57	6	4	75
Dn25	92	74	8	8	98

螺纹式采样阀 Threaded Sample Valve

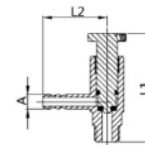

Size	A	L1	L2
1/2"	12	89	52
3/4"	12	89	52

卡箍式采样阀 Clamped Sample Valve

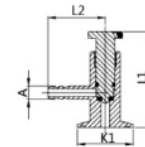

Size	A	K1	L1	L2
1/2"	12	50.5	89	52

焊接式采样阀 Welded Sample Valve

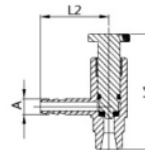

Size	A	L1	L2
1/2"	12	89	52

液位计 Level Gauge

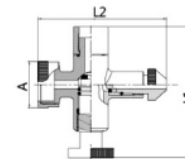

Size	A	L1	L2
1/2"	37.5	106	104



Sanitary Cleaning Ball Sight Glass

卫生级清洗器/视镜系列



卫生级视镜 Sanitary Sight Glass

应用:

为了更加直观方便的观察设备运行状态以及系统工作状态,视镜被广泛应用于酿酒、饮料、制药和乳制品等领域。

Application:

The sight glass is widely used in food, wine-produceing, beverage, and pharmacy industries etc. for it is convenient to view the condition of equipment running state and system work state.

设计标准:

能提供直通视镜、带灯视镜以及四通视镜。直通视镜可水平或垂直安装,可以360°通过玻璃防护去观察,特别适合管线的在线观察。带灯视镜为活接型视镜,具有在暗光下可灯照观察以及拆装更换方便等特点,适合罐类设备的观察。

Standard Design:

have straight sight glass, sight glass with lamp and cross sight glass. The straight sight glass can be installed in horizontal or vertical, it also can 360° view through the glass defence. It is suitable for on-line view of the pipeline. Sight glass with lamp is a type of sight glass with union, it can work under the lower light according the lamp, and disassembling easy. So it is suitable to the view of tank equipment.

技术参数:

工作温度: -20~+135°C (密封件为EPDM时)

Technical Data:

Working temperature:
-20~+135°C (when the sealing is EPDM.)



材料:

钢质部件: 304或316L

视镜材质: 硼化硅玻璃(直通视镜)

硼化硅玻璃、钢化玻璃(活接视镜)

密封件: EPDM (标配) NBR, PTFE (选配)

Material:

Steel parts: 304 or 316L

The material of GLASS LENS glass: silicon boride glass (straight sight glass)

silicon boride, tempered glass (sight glass with union)

Sealing elements: EPDM (standard configuration)
NBR, PTFE (match)

螺纹式直通视镜 Threaded Straight Sight Glass

DIN

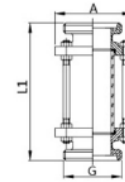

Size	L1	G	A
DN25	154	RD52×1/6	78
DN32	156	RD58×1/6	82
DN40	156	RD65×1/6	88
DN50	166	RD78×1/6	110
DN65	176	RD95×1/6	127
DN80	184	RD110×1/4	140
DN100	200	RD130×1/4	160

直通焊接式视镜 Welded Straight Sight Glass

DIN

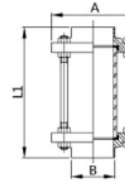

Size	L1	B	A
DN25	140	28	78
DN32	140	34	80
DN40	140	40	80
DN50	142	52	100
DN65	144	70	127
DN80	148	85	140
DN100	152	104	160

卡箍式直通视镜 Clamped Straight Sight Glass

DIN

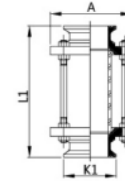

Size	A	K1	L1
Dn25	78	50.5	156
DN32	80	50.5	156
DN40	80	50.5	160
DN50	100	64	166
DN65	127	91	168
DN80	140	106	172
Dn100	160	119	194

球形视镜 Spherical Sight Glass

DIN

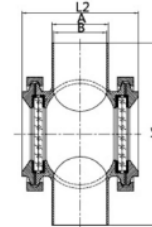

Size	A	B	L2	L1
Dn25	28	25	67	90
DN32	34	31	78	100
DN40	40	37	83	130
DN50	52	49	99	165
DN65	70	66	125	205
DN80	85	81	145	250
Dn100	104	100	168	300

活接视镜 Union-Type Sight Glass

DIN

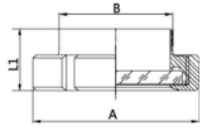

Size	A	DIN11851		DIN11850	
		L1	B	L1	B
Dn25	62	35	31	28	28
DN32	68	38	37	28	34
DN40	78	40	43	28	40
DN50	92	42	55	28	52
DN65	110	47	72	30	70
DN80	126	52	87	33	85
DN100	146	62	106	38	104
DN125	178	52	132	40	129
Dn150	208	66	157	42	154

视镜 Sight Glass

3A/SMS/ISO/IDF

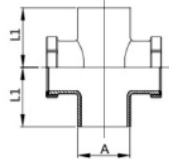

Size	L1	A
1"	33.5	25.4
1 1/4"	38	31.8
1 1/2"	48.5	38.1
2"	60.5	50.8
2 1/2"	83.5	63.5
3"	88.5	76.2
4"	127	101.6

直通焊接式视镜 Welded Straight Sight Glass

3A/SMS/ISO/IDF

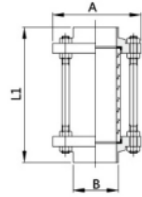

Size	L1	B	A
1"	140	25.4	78
1 1/4"	140	31.8	80
1 1/2"	140	38.1	80
2"	140	50.8	100
2 1/2"	144	63.5	117
3"	144	76.2	129
3 1/2"	148	89	140
4"	152	101.6	160

卡箍式直通视镜 Clamped Straight Sight Glass

3A/SMS/ISO/IDF

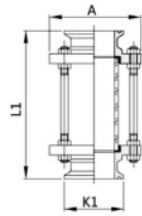

Size	L1	K1	A
1"	156	50.5	78
1 1/4"	156	50.5	78
1 1/2"	160	50.5	80
2"	166	64	100
2 1/2"	168	77.5	117
3"	172	91	129
3 1/2"	178	106	140
4"	194	119	160

卡箍式直通视镜 Clamped Straight Sight Glass

SMS

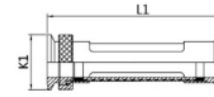

Size	L1	K1
25	155	50.5
32	155	50.5
38	155	50.5
51	155	64

活接视镜 Union-Type Sight Glass

SMS

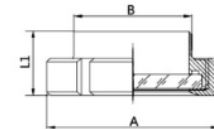

Size	L1	B	A
25	25	25.4	50
32	25	31.8	60
38	28	38.1	72
51	28	50.8	82
63	32	63.5	98
76	33	76.2	114
89	34	88.9	125
102	36	101.6	150

无电缆灯视镜 No Cable Light Endoscopy

DIN

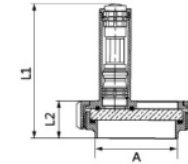

Size	A	L1	L2
Dn65	70	121.5	31
DN80	85	123.5	33
DN100	104	126.5	37
DN125	129	127.5	38
Dn150	154	133.5	45

带灯视镜 Sight Indicator Sight Glass

DIN

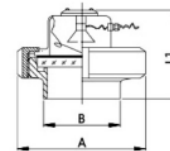

Size	L1	B	A
Dn80	90	87	126
DN100	100	106	146
DN125	90	132	178
Dn150	96	157	208

Sanitary Cleaning Ball

应用:

旋转式清洗球:是一种旋转喷头,它使用清洁剂对储罐进行全面清洗和喷射。由于此设备在低压下使用的洗涤液量较少,因此它是传统固定喷球的一种有效替代产品。旋转头中采用双滚珠轴承,使该类型清洗球系列适用于所有卫生级和工业级清洗应用领域,包括储罐、反应器和容器等所有卫生级和工业级用品的清洗任务。

固定式清洗球:是食品和饮料行业中一种用来清洗储罐的固定喷球。固定喷球用于要求较低的清洗任务。



Application:

Rotary cleaning ball: it's a kind of rotary sprayer, which use cleanser to spray strongly and clean inside of the tank. It is one which is effective replace the traditional fixed cleaning ball for it can be used under low pressure with less detergent. The rotary sprayer use dual ball bearing, so it is suitable for the sanitary and industrial application, include tank, reactor, vessel etc.

Fixed cleaning ball: its a type of fixed spray ball of cleaning storage tank. The fixed spray ball is use to cleaning task with lower requirement.

技术数据:

重量:视具体规格
 润滑:通过清洗液自润滑
 工作压力:1-3Bar
 最高工作温度:95°C
 最高环境温度:140°C
 湿润半径:最大3m
 喷射清洗半径:最大有效半径2m
 接口:焊接式、快装式和螺纹式

工作原理:

旋转式清洗球:清洗液通过自身的动力使清洗球喷头旋转,扇形喷流在整个储罐会反应皿中形成涡流,由此有效的清除留在容器表面的残余产品,达到清洁作用。

固定式清洗球:清洗球通过清洗球的喷头小口,形成向四周喷射的喷流,从而清除留在容器表面的残余产品,达到清洁作用。

Technical Data:

As per specification Lubrication by the cleaner itself.
 Working pressure: 1-3Bar
 MAX. working temperature: 95°C
 MAX. ambient temperature: 140°C
 Moist radius: MAX.3M
 Inject cleaning radius: MAX. effective radius 2M
 Connector: weld, clamp, thread.

Work Principle:

Rotary cleaning ball: The cleaning solution make the sprayer rotary by it's motive power, then the fan jet created the whole tank and reactor with vortex. In that way, clean the remains of vessel surface effectively, reach the function of cleaning.

Fixed cleaning ball: the cleaning ball is through the sprayer small hole, create the injection all around. In that way, clean the remains of vessel surface effectively, reach the function of cleaning.

设计标准:

生产的清洗球系列均符合 DIN、3A、SMS、ISO/IDF等生产标准。

Design Standard:

have the standard of cleaning ball series as follows: DIN, 3A, SMS, ISO/IDF

材料:

接头:304/316L
 喷头:304/316L

Material:

Ferrule: 304/316L
 Sprayer: 304/316L

螺纹式旋转式清洗球 Threaded Rotary Cleaning Ball

Size	A	L1
1"	53	140
1 1/4"	53	160
1 1/2"	53	170
2"	76	192
2 1/2"	910	220

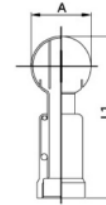

技术参数 Technical Data

Size	Pressure (bar)	Cleaning radius (m)	Fluxation (m ³ /h)
1"-1.5"	2	1.25	12
2"	2	1.5	38
2.5"	2	2	38

卡箍式旋转式清洗球 Clamped Rotary cleaning ball

Size	A	L1
1"	53	138
1 1/4"	53	138
1 1/2"	53	138
2"	63	168
2 1/2"	76	190

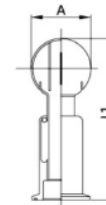

技术参数 Technical Parameter

Size	Pressure (bar)	Cleaning radius (m)	Fluxation (m ³ /h)
1"-1.5"	2	1.25	12
2"	2	1.5	38
2.5"	2	2	38

插销式旋转式清洗球 Bolted Rotary Cleaning Ball

Size	A	L1
1"	53	135
1 1/4"	53	137
1 1/2"	53	137
2"	63	168
2 1/2"	76	190



技术参数 Technical Parameter

Size	Pressure (bar)	Cleaning radius (m)	Fluxation (m ³ /h)
1"-1.5"	2	1.25	12
2"	2	1.5	38
2.5"	2	2	38

焊接式旋转清洗球 Welded Rotary Cleaning Ball

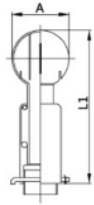

Size	A	L1
1"	53	143
1 1/4"	53	145
1 1/2"	53	145
2"	63	180
2 1/2"	76	200

技术参数 Technical Parameter

Size	Pressure (bar)	Cleaning radius (m)	Fluxation (m ³ /h)
1"-1.5"	2	1.25	12
2"	2	1.5	38
2.5"	2	2	38

焊接式固定清洗球 Welded Fixed Cleaning Ball

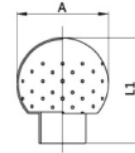

Size	A	L1
1"	53	72
1 1/2"	63	85
2"	91	87
2 1/2"	100	102

技术参数 Technical Parameter

Size	Pressure (bar)	Cleaning radius (m)	360°/180° Fluxation(m ³ /h)
1"	2.5	1-1.25	17/10
1.1/4"-11/2"	2.5	1.25-1.75	23/17
2"	3.5	2-3	55/38
2 1/2"	3.5	3-3.5	58/41

螺纹式固定清洗球 Threaded Fixed Cleaning Ball

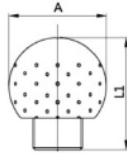

Size	A	L1
1"	63	72
1 1/4"	76	85
1 1/2"	76	87
2"	91	102

技术参数 Technical Parameter

Size	Pressure (bar)	Cleaning radius (m)	360°/180° Fluxation(m ³ /h)
1"	2.5	1-1.25	17/10
1.1/4"-11/2"	2.5	1.25-1.75	23/17
2"	3.5	2-3	55/38
2 1/2"	3.5	3-3.5	58/41

焊接式固定清洗球 Welded Bolted Fixed Cleaning Ball

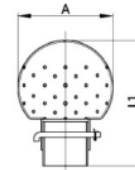

Size	A	L1
1"	63	95
1 1/2"	76	110
2"	91	125
2 1/2"	100	135

技术参数 Technical Parameter

Size	Pressure (bar)	Cleaning radius (m)	360°/180° Fluxation(m ³ /h)
1"	2.5	1-1.25	17/10
1.1/4"-11/2"	2.5	1.25-1.75	23/17
2"	3.5	2-3	55/38
2 1/2"	3.5	3-3.5	58/41

卡箍式固定清洗球 Clamped Fixed Cleaning Ball

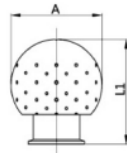

Size	A	L1
1"	63	80
1 1/4"	76	93
1 1/2"	76	93
2"	91	108
2 1/2"	100	115

技术参数 Technical Parameter

Size	Pressure (bar)	Cleaning radius (m)	360°/180° Fluxation(m ³ /h)
1"	2.5	1-1.25	17/10
1.1/4"-11/2"	2.5	1.25-1.75	23/17
2"	3.5	2-3	55/38
2 1/2"	3.5	3-3.5	58/41

螺纹式旋转清洗器 Threaded Rotary Cleaning Ball

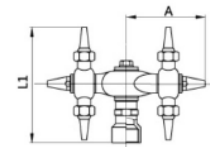

Size	A	L1	Pressure (bar)	Cleaning radius (m)	Fluxation (m ³ /h)
1"	118	165	1.5-2	2-3	23
1 1/2"	142	189	1.8-2.5	3.5-3	38
2"	145	191	2.5-3	3.5-4	60